

EUROBLOC *VT*[®]

Electric wire rope hoist
for load from 800 up to 80 000 kg

 **VERLINDE**[®]

LIFTING EQUIPMENT

Ref : 02 2016 333 UGB

The leading French manufacturer of lifting equipment

Leading french manufacturer of lifting equipment. VERLINDE produce in large batches electric wire rope hoist, electric chain hoist, electric belt hoist, electric winches, jib cranes, and cranes components in their fully modernized and enlarged production center of VERNOUILLET (France).

From CAD/CAM design to production by machines amongst the most modern in Europe combined with know-how from a skilled staff, each lifting equipment showing the VERLINDE brand ensures reliability and quality to users.

New products, new concepts

VERLINDE has always been among the first companies to introduce new ideas for the innovation of hoisting units with a hook (more than 70 patents taken out in France and around the world). The new EUROBLOC VT electric wire rope hoist has been created within this avant-garde spirit, as it accounts for a total of 13 patents on its own.

The EUROBLOC VT electric wire rope hoist is, as of now, the only hoisting unit with wire rope and a hook that offers, in its standard version:

- > Hook approach, "C" dimensions and the "F" approach distance of the hoist are the smallest available on the market (fig. 2).
- > The pulley block presents only a slight lateral shift during hoisting motion (virtually vertical lifting) (fig. 1).
- > The possibility to adjust speed while travelling (fig. 3).

And more equipment to be discovered in the pages that follow.

fig. 1



fig. 2

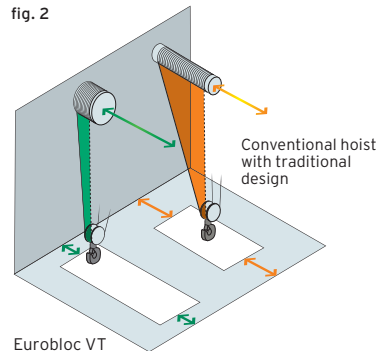
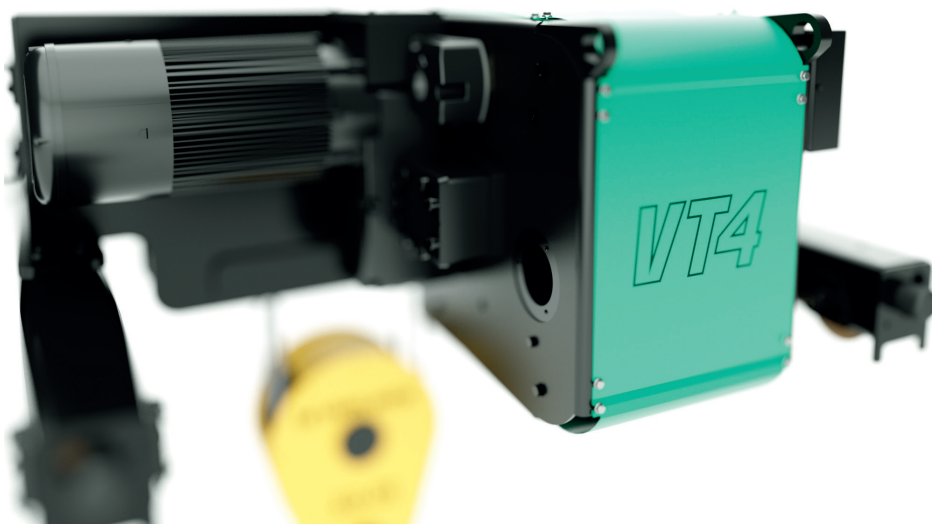
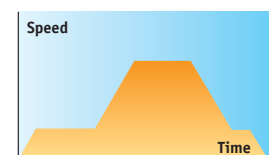
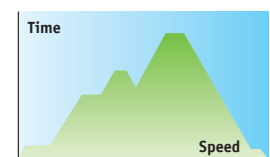

fig. 3





Customised installations

Foot mounted.



Monorail trolley with standard headroom (HPN).

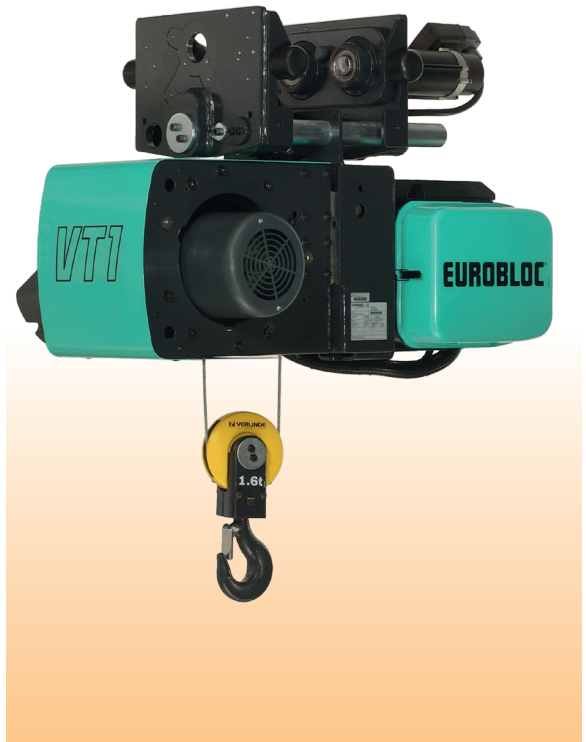

Double girder trolley high, medium and low version.





➤ Monorail trolley with short headroom (HPR).

➤ Monorail trolley with short headroom (HPR) and inverter on lifting motion (option).

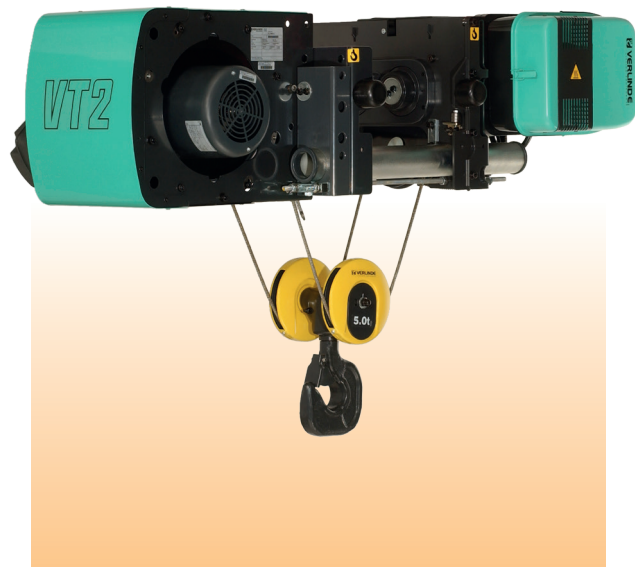
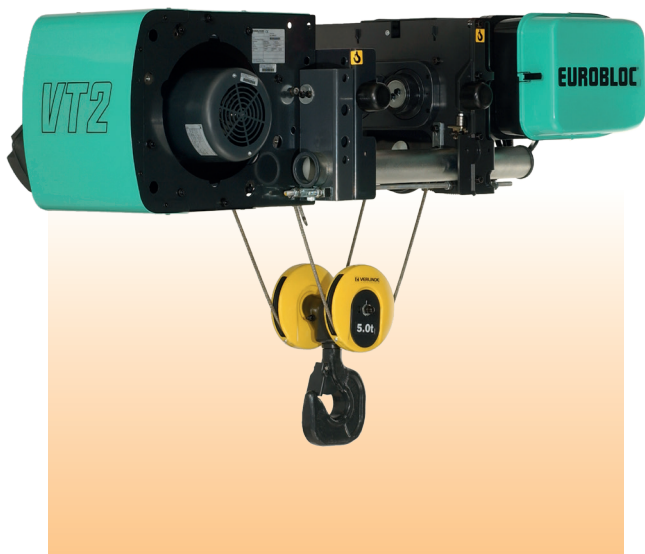

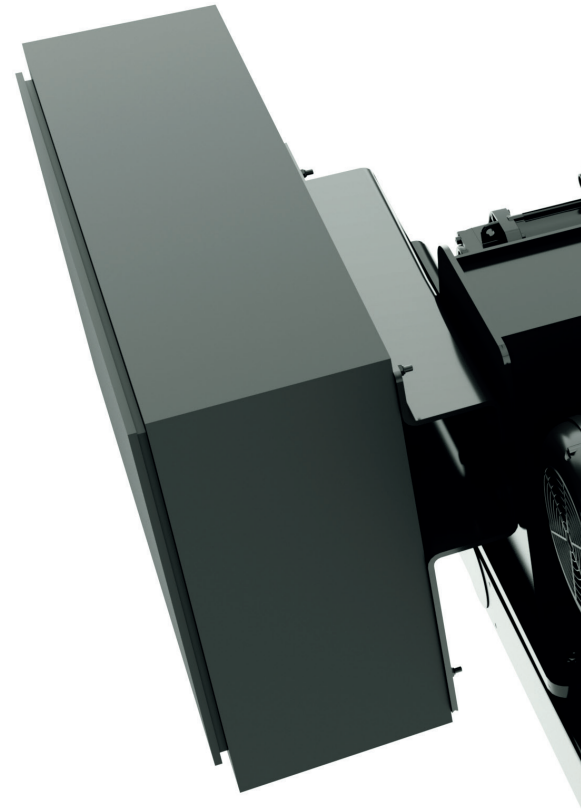

+ safety

Travelling. Variable travelling speed for precise positioning of loads.

Wire rope. In galvanized steel as a standard, high safety factor (factor 4,6 - FEM 2m).

Electrical cubicle. The cover can be folded back so that you can store your tools for maintenance (the cover has two steel safety wires to prevent it from falling).

MT2. Electronic control of the recording of hoist solicitation status (as standard on VT4&5).

MT3. Electronic overload device and SWP calculation solicitation status (as standard on VT1,2&3).

Electrical. Low voltage control for more safety.

Traverse wheels. The 4 steering wheels are fully streamlined for improved safety.

Hook and pulley block. Rotating hook and pulley block with safety latch.

+ ergonomics

Hook and pulley block. Ergonomical hook (area to grab and hold).

Push button box. Made with tinted polypropylene, grounded, with double insulation, ergonomic (IP 65 protection). Optional load display available.

Electrical cubicle. Located on the side of the hoist, easily accessible. The open / close system uses a quick closure method.

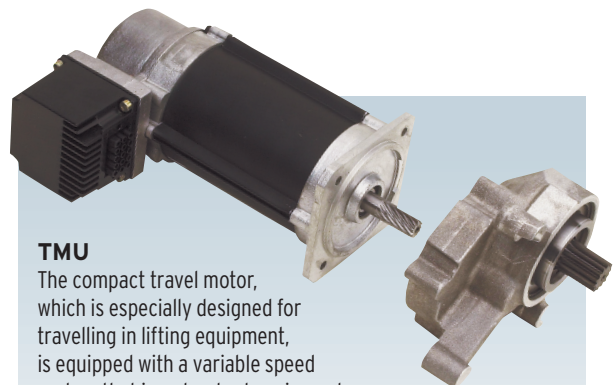
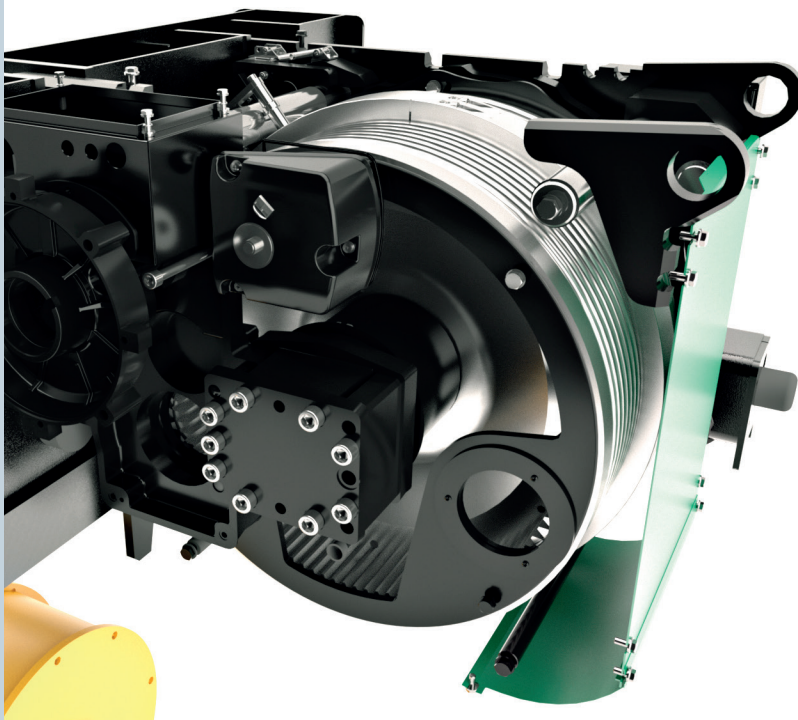

TMU

The compact travel motor, which is especially designed for travelling in lifting equipment, is equipped with a variable speed system that is a standard equipment. Maximum speed range is 2 to 32 m/min. IP 55 protection. The motor is designed to ease any necessary maintenance:

- > "Intelligent" easy system for motor positioning and assembly onto the trolley.
- > The motor receives power from a single plug that can be unbound easily.



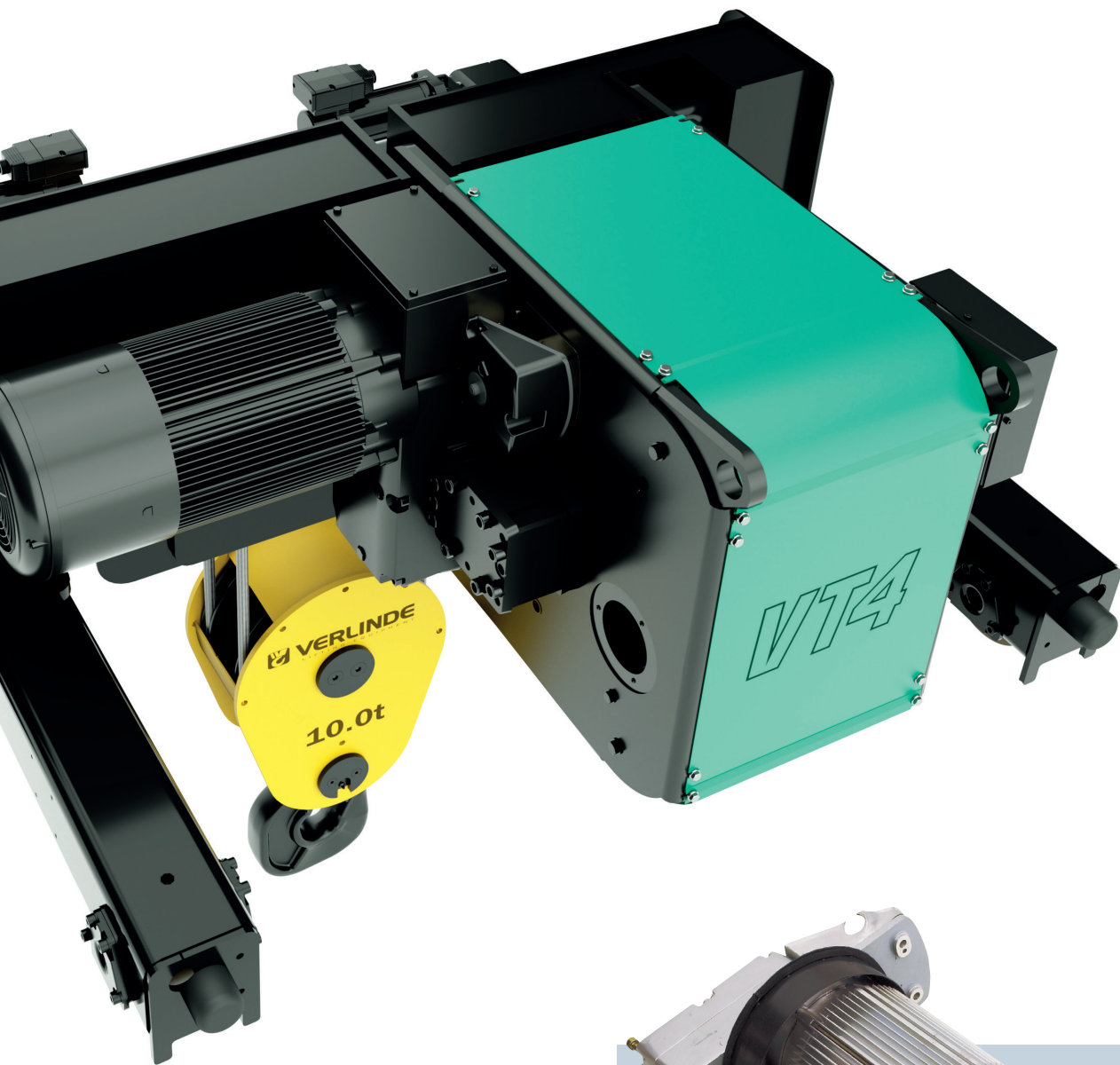

easy maintenance

Hoisting motor. Motor cooling increased by 30 % (tunnel effect).

Hoisting brake. The brake is tested for hoist longevity under normal use conditions.

Steering motor-reducer. Steering reducer with one rail and a permanently lubricated connection.

Drum. The drum has been completely covered for better protection.

Rope guide. Built "without spring" so that it can be more easily replaced during maintenance.

Electrical cubicle. The wires go in and out by means of steel plugs that can be unbound and that are built into the case.

MT2. Calculation of the SWP (Safe Working Period) deliver as standard on VT4&5.

MT3. Calculation of the SWP (Safe Working Period) deliver as standard on VT1,2 & 3. Assembly is in modules, for easier management of spare parts for replacement.

Surface treatment. 2- component epoxy paint with 120 μ for greater protection.

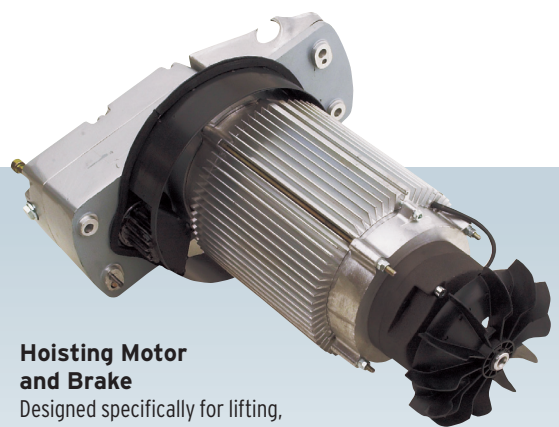

Hoisting Motor and Brake

Designed specifically for lifting, the 2-speed hoisting motor comes with all the necessary protections:

- > Type IP 55 protection and F insulation class.
- > Bimetal sensor.
- > Cooling fins enlarged significantly to encourage heat dissipation.

Hoisting drum

There is a special patent for drum assembly and drum rotation without ball bearings.

Advantage: this prevents grease and steel particles from falling into the motor.



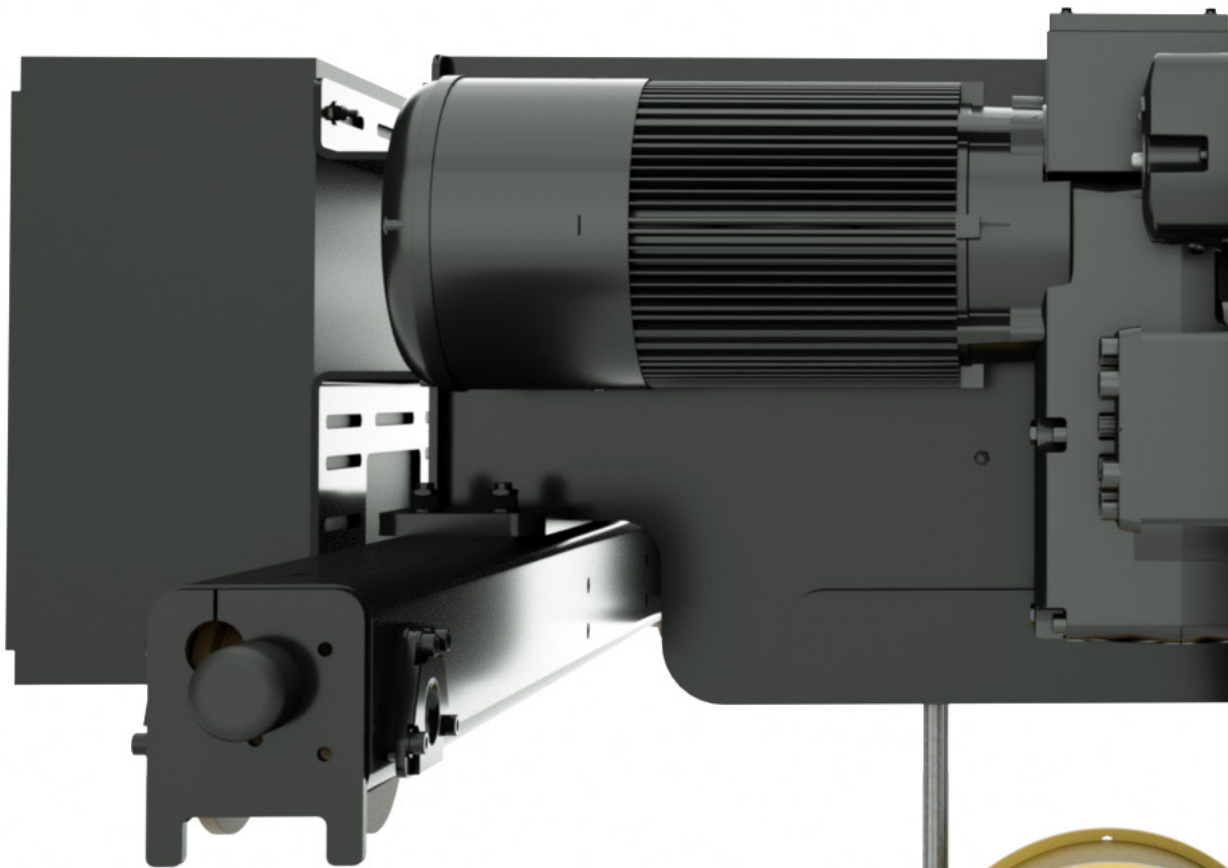

savings

Hoisting motor. 60 % operating factor and tropicalised as a standard for greater longevity.

Travelling motor. Tropicalised as a standard for greater longevity.

Pulley block. The best "C" dimension on the market for optimal use of the size of your buildings and optimal use of work areas.

Travelling. Variable travelling speed to reduce wear on steering rollers.

Load limiter. As ordered by the directive on "Machines" (required equipment). All EUROBLOC VTs are equipped with a load limiter as a standard (safety measure in the event of hoist overload). For greater longevity.

Hook and pulley block. Doesn't take up much space, permanently lubricated rollers, pulleys are in GGG cast iron, very resistant. A high pulley/wire rope diameter ratio gives the wire rope greater longevity.

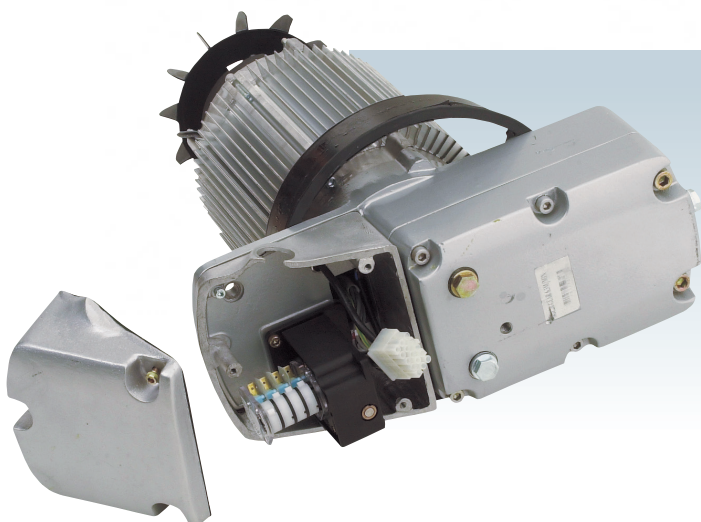

Gear limit switches

The limit switch with 4 cams can be accessed on the gear unit and is used for managing the upper and lower limit switches of the hook, switching from low to high speed, and for managing phase reversals.

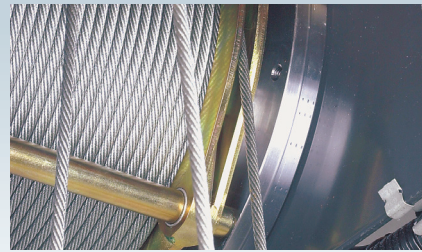

Rope guide

New rope guided system "very high performance" for difficult environments.



MT2



MT3

MT2/MT3

EUROBLOC VT are equipped with the MONITOR 2 (Electronic control of the recording of the hoist's tractive effort states: SWP, time running, starts, overloads, temperature, load, brake, etc.) or MT3 which offer calculation of the Safe Working Period (SWP).

+ high technology

Pulley block. Only a small shift of the pulley block for hoisting (lifting is almost perfectly centred).

Rope guide. The guidance system does not get dirty, which allows for use in any type of environment.

Drum. A very high wire rope / drum diameter ratio (twice as large as the standard one), which:

- > Increases the longevity of the wire rope.
- > Reduces the approach data of the hoist.
- > Reduces the "C" approach data of the hook.

Electrical case. Quite large, it is equipped with the speed variation module as a standard.

Lifting gearbox. Direct impulse gearbox unit, helicoid toothed gears, permanently lubricated, detector to prevent pressure overload.

Optimal positioning of steering rollers. The 4 steering rollers equally share the load in order to optimise your tracks.



Options

- > Non standard rail width.
 - > Special rail gauge.
 - > Higher travelling speed.
 - > Radio remote control.
 - > Travelling limit switch.
 - > Derailment catches on double girder trolley.
 - > Boogies trolley (only with HPN).
 - > Missing phase control.
 - > Monitor 2 (MT2).
 - > 2 or 3 steps overload device.
 - > Overload device temporization.
 - > Optical and audible warning connected to overload limit switch.
 - > Non standard main voltage.
 - > Rain cover.
 - > Klaxon on pendant box.
 - > Explosion proof and / or spark proof version.
 - > Load indication device.
 - > Motors thermal protection.
 - > Class H motors.
 - > Heating device on motor.
 - > Stainless steel hoist electrical cubicle IP 55 or IP 65.
- > CSA electrical control.
 - > Hook operated upper limit switches.
 - > Ramshorn hook.
 - > Additional brake.
 - > Lifting variable speed.
 - > Crash protection with electronic cell.



Standards and hoisting regulations



CE directive. Since December 2009, the European Machinery Directive (2006/42/EC) applies to the sale and assembly of all new machines marketed from 2010. The new decree is complementary to the former Directive, made up of 600 standards issued in 1995. That directive obliges that machine constructors ensure that their machinery complies with certain regulations, standards, national legislations and technical specifications.

F.E.M. European lifting equipment association.

S.W.P. Safe Working Period. A Safe Working Period is calculated for each electrical hoist unit according to the average operating time of the hoisting equipment, load capacity and class of application.

After this period, a general service carried out by the constructor is necessary.

Class of operation. According to FEM classification, two fundamental criteria must be taken into account : the type of duty and the class of duty (according to average daily operation time average load).

ISO standard. Classes of operation can also be defined according to ISO grouping (1Am =M4, 2m =M5, 3m =M6, etc.).

Type of duty.

> **Light service.** Equipment rarely subject to maximum load and frequently to very little load.

> **Medium service.** Equipment rarely subject to maximum load and frequently to very little load.

> **Heavy service.** Equipment frequently subject to maximum load and frequently to medium load.

> **Very heavy service.** Equipment frequently subject to maximum or near maximum load.

Average daily operating time (hours)				≤0,5		≤1		≤2		≤4		≤8		≤16	
				V0,25	T2	V0,5	T3	V1	T4	V2	T5	V3	T6	V4	T7
Type of service	1	L1	Light					1Bm	M3	1Am	M4	2m	M5	V4	M6
	2	L2	Medium			1Bm	M3	1Am	M4	2m	M5	3m	M6		
	3	L3	Heavy	1Bm	M3	1Am	M4	2m	M5	3m	M6				
	4	L4	Very heavy	1Am	M4	2m	M5	3m	M6						
Group								1Bm	M3	1Am	M4	2m	M5	3m	M6
Duty factor*								25 %		30 %		40 %		50 %	
Number of star starts per hour								150		180		240		300	

■ FEM 9511 standards classification. ■ ISO standards classification.

* Duty factor in % = $\frac{\text{Hoisting time} + \text{lowering time}}{\text{Hoisting time} + \text{idle time} + \text{lowering time} + \text{idle time}} \times 100$

EUROBLOC VT range

Hoist codification	Load (FEM/kg)			H.O.L. (m)	Lifting speeds (m/mn)	Trolleys					
	1Am	2m	3m			Fixed	Monorail		Double girder trolley		
							HPR	HPN	High	Med.	Low
VT10211--N P1		1 000	800	12	10 / 1,6	*	*	*	*	*	
VT10211--N P2		1 600	1 250	12 - 19	10 / 1,6	*	*	*	*	*	
VT10211--R P2		1 600	1 250	12 - 19	12,5 / 2	*	*	*	*	*	
VT10411--N P1		2 000	1 600	6 - 9,5	5 / 0,8	*	*	*	*	*	
VT10411--N P2		3 200	2 500	6 - 9,5	5 / 0,8	*	*	*	*	*	
VT10411--R P2		3 200	2 500	6 - 9,5	6,3 / 1	*	*	*	*	*	
VT20211--N P3		2 500	2 000	12 - 18 - 24 - 30*	10 / 1,6	*	*	*	*	*	
VT20211--R P4		2 500	2 000	12 - 18 - 24 - 30*	16 / 2,6	*	*	*	*	*	
VT20211--L P3	3 200			12 - 18 - 24 - 30*	8 / 1,3	*	*	*	*	*	
VT20411--N P3		5 000	4 000	6 - 9 - 12 - 15*	5 / 0,8	*	*	*	*	*	
VT20411--R P4		5 000	4 000	6 - 9 - 12 - 15*	8 / 1,3	*	*	*	*	*	
VT20411--L P3	6 300			6 - 9 - 12 - 15*	4 / 0,7	*	*	*	*	*	
VT20611--N P3		7 500		6 - 8 - 10	3,2 / 0,5	*	*	*	*	*	
VT20611--R P4		7 500		6 - 8 - 10	5 / 0,8	*	*	*	*	*	
VT20811--N P3	10 000	8 000		4,5 - 6 - 7,5	2,5 / 0,4	*	*	*	*	*	
VT20811--R P4	10 000	8 000		4,5 - 6 - 7,5	4 / 0,7	*	*	*	*	*	
VT30211--N P5		5 000	4 000	18 - 24 - 32 - 40*	10 / 1,6	*	*	*	*	*	
VT30211--R P6		5 000	4 000	18 - 24 - 32 - 40*	16 / 2,6	*	*	*	*	*	
VT30211--L P5	6 300			18 - 24 - 32 - 40*	8 / 1,3	*	*	*	*	*	
VT30411--N P5		10 000	8 000	9 - 12 - 16 - 20*	5 / 0,8	*	*	*	*	*	
VT30411--R P6		10 000	8 000	9 - 12 - 16 - 20*	8 / 1,3	*	*	*	*	*	
VT30411--L P5	12 500			9 - 12 - 16 - 20*	4 / 0,7	*	*	*	*	*	
VT30611--N P5		15 000		4,5 - 6 - 8 - 10	3,2 / 0,5	*	*	*	*	*	
VT30611--R P6		15 000		4,5 - 6 - 8 - 10	5 / 0,8	*	*	*	*	*	
VT30811--N P5	20 000	16 000		4,5 - 6 - 8 - 10	2,5 / 0,4	*	*	*	*	*	
VT30811--R P6	20 000	16 000		4,5 - 6 - 8 - 10	4 / 0,7	*	*	*	*	*	
VT30421--N P5		5 000	4 000	10 - 14 - 19 - 26 - 35 - 47	10 / 1,6	*	*	*	*	*	
VT30421--R P6		5 000	4 000	10 - 14 - 19 - 26 - 35 - 47	16 / 2,6	*	*	*	*	*	
VT30821--N P5		10 000	8 000	5 - 7 - 9,5 - 13 - 17,5 - 23,5	5 / 0,8	*	*	*	*	*	
VT30821--R P6		10 000	8 000	5 - 7 - 9,5 - 13 - 17,5 - 23,5	8 / 1,3	*	*	*	*	*	
VT31221--N P5		15 000	12 000	4,5 - 6,5 - 8,5 - 11,5 - 15,5	3,2 / 0,5	*	*	*	*	*	
VT31221--R P6		15 000	12 000	4,5 - 6,5 - 8,5 - 11,5 - 15,5	5 / 0,8	*	*	*	*	*	
VT31621--N P5	20 000	16 000		4,5 - 6,5 - 8,5 - 11,5	2,5 / 0,4	*	*	*	*	*	
VT31621--R P6	20 000	16 000		4,5 - 6,5 - 8,5 - 11,5	4 / 0,7	*	*	*	*	*	
VT40211--L P6	10 000	8 000	6 300	16,4 - 22 - 28,6 - 37	8 / 1,3	*	*	*	*	*	
VT40211--N P6		8 000	6 300	16,4 - 22 - 28,6 - 37	10 / 1,6	*	*	*	*	*	
VT40211--N P7	10 000			16,4 - 22 - 28,6 - 37	10 / 1,6	*	*	*	*	*	
VT40211--R P7		8 000	6 300	16,4 - 22 - 28,6 - 37	12,5 / 2	*	*	*	*	*	
VT40411--L P6	20 000	16 000	12 500	8,2 - 11 - 14,3 - 18,5 - 23,8	4 / 0,6	*	*	*	*	*	
VT40411--N P6		16 000	12 500	8,2 - 11 - 14,3 - 18,5 - 23,8	5 / 0,8	*	*	*	*	*	
VT40411--N P7	20 000			8,2 - 11 - 14,3 - 18,5 - 23,8	5 / 0,8	*	*	*	*	*	
VT40411--R P7		16 000	12 500	8,2 - 11 - 14,3 - 18,5 - 23,8	6,3 / 1	*	*	*	*	*	
VT40611--L P6	30 000	25 000		5,5 - 7,3 - 9,5 - 12,3 - 15,9	2,5 / 0,4	*	*	*	*	*	
VT40611--N P6		25 000		5,5 - 7,3 - 9,5 - 12,3 - 15,9	3,2 / 0,5	*	*	*	*	*	
VT40611--N P7	30 000			5,5 - 7,3 - 9,5 - 12,3 - 15,9	3,2 / 0,5	*	*	*	*	*	
VT40611--R P7		25 000		5,5 - 7,3 - 9,5 - 12,3 - 15,9	4 / 0,6	*	*	*	*	*	
VT40811--L P6	40 000			5,8 - 7,2 - 9,3 - 11,9	2 / 0,3	*	*	*	*	*	
VT40811--N P7	40 000			5,8 - 7,2 - 9,3 - 11,9	2,5 / 0,4	*	*	*	*	*	
VT41011--N P7		18m / 50 000		5,8 - 7,2 - 9,3 - 11,9	2 / 0,3	*	*	*	*	*	
VT40421--L P6	10 000	8 000	6 300	20 - 25,7 - 33	8 / 1,3	*	*	*	*	*	
VT40421--N P6		8 000	6 300	20 - 25,7 - 33	10 / 1,6	*	*	*	*	*	
VT40421--N P7	10 000			20 - 25,7 - 33	10 / 1,6	*	*	*	*	*	
VT40421--R P7		8 000	6 300	20 - 25,7 - 33	12,5 / 2	*	*	*	*	*	
VT40821--L P6	20 000	16 000	12 500	10 - 12,8 - 16,5 - 21,2 - 27,9 - 33,7	4 / 0,6	*	*	*	*	*	
VT40821--N P6		16 000	12 500	10 - 12,8 - 16,5 - 21,2 - 27,9 - 33,7	5 / 0,8	*	*	*	*	*	
VT40821--N P7	20 000			10 - 12,8 - 16,5 - 21,2 - 27,9 - 33,7	5 / 0,8	*	*	*	*	*	
VT40821--R P7		16 000	12 500	10 - 12,8 - 16,5 - 21,2 - 27,9 - 33,7	6,3 / 1	*	*	*	*	*	
VT41221--L P6	30 000	25 000		6,6 - 8,5 - 11 - 14,1 - 18,6 - 22,4	2,5 / 0,4	*	*	*	*	*	
VT41221--N P6		25 000		6,6 - 8,5 - 11 - 14,1 - 18,6 - 22,4	3,2 / 0,5	*	*	*	*	*	
VT41221--N P7	30 000			6,6 - 8,5 - 11 - 14,1 - 18,6 - 22,4	3,2 / 0,5	*	*	*	*	*	
VT41221--R P7		25 000		6,6 - 8,5 - 11 - 14,1 - 18,6 - 22,4	4 / 0,6	*	*	*	*	*	
VT41621--L P6	40 000			6,4 - 8,2 - 10,6 - 13,9 - 16,8	2 / 0,3	*	*	*	*	*	
VT41621--N P7	40 000			6,4 - 8,2 - 10,6 - 13,9 - 16,8	2,5 / 0,4	*	*	*	*	*	
VT42021--N P7		18m / 50 000		6,6 - 8,5 - 11,1	2 / 0,3	*	*	*	*	*	
VT50421--	20 000	16 000	12 500	4,5 - 6,7 - 10,1 - 13,5	**	*	*	*	*	*	
VT50821--	40 000	32 000	25 000	6,2 - 8,2 - 10,9 - 14,4	**	*	*	*	*	*	
VT51221--	60 000	50 000		5,9 - 7,7 - 10 - 13,2	**	*	*	*	*	*	
VT51621--	80 000			5,8 - 7,5 - 9,9 - 12	**	*	*	*	*	*	

*Not available in HPR version.

**Consult us.



VERLINDE is:

- The leading French manufacturer and exporter of lifting and handling equipment.
- A comprehensive range of 30 groups of lifting equipment from 60 to 250,000 kg.
- ISO 9001 Quality control certified and ISO 14001 Environmental Management Systems.

In France:

A sales network and after sales service points, EUROPONT travelling crane construction plants and a distributor network.

Abroad:

A customer service in more than 92 countries.

References

Metallurgy, Mechanics, Nuclear

ArcelorMittal, Unimetal, Stein, NFM, Framatome, Alstom

Chemicals, Petrochemicals industry

Sanofi Aventis, Total, Du Pont De Nemours

Aeronautical industry

Aérospatiale, Airbus, Snecma, Eurocopter, Air France, Aéroport de Paris, Dassault Aviation



Agri-food industry

Nestlé, Danone, Bel, Palamatic, Tetrapak, Lactalis

Automobile industry

Renault, Peugeot, Citroën, Scania, Ford, RVI, Volkswagen, Michelin, Massey Ferguson, Manitou, Toyota Industrial Equipment

Other sectors

EDF, SNCF, RATP, Spie, Degremont, Eiffage, Polysius, Baudin Chateauneuf



NEXT LEVEL
PARTNERSHIP

2, boulevard de l'Industrie | B.P. 20059 | 28509 Vernouillet cedex | France
Phone : (33) 02 37 38 95 95 | Fax : (33) 02 37 38 95 99 | Internet : www.verlinde.com

