

SHER2M electric chain hoist short headroom

- ▶ Up to 5,000 kg load capacity
- ▶ 380 - 440 V / 50 Hz
- ▶ 24 V control voltage
- ▶ Frequency inverter for precise positioning of the load
- ▶ Single and dual lifting and traveling speed
- ▶ Operating hours counter / load cycle counter
- ▶ Range limit switch for lifting / lowering
- ▶ Thermal motor protection
- ▶ Electromagnetic brake
- ▶ Nickel-plated load chain grade T, series DAT (G80) in accordance with standard EN 818-7

Options

- ▶ Fall protection device and bumpers
- ▶ Limit Lock - Individual programmable hook position limits (page 42 – 43)
- ▶ Stepless Speed - Infinitely variable speed control (page 45 – 45)





**Usage of the
effective lifting
height**



Optimized headroom C due to special chain guide solution

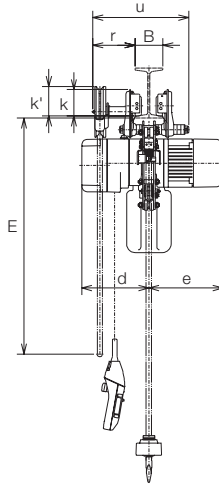

Geared trolley

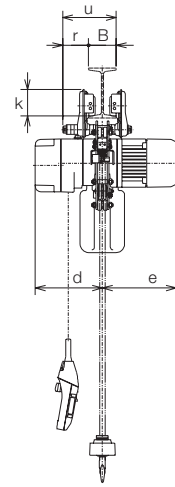

Plain trolley

Headroom comparison

Type	Load capacity	Headroom C (mm)		
		A SHER2M	B Standard ER2M	Difference (A-B)
003IS	250	265	375	-110
005IL	500	285	395	-110
005IS	500	285	395	-110
010IL	1,000	345	435	-90
010IS	1,000	345	435	-90
016IS	1,600	435	505	-70
020IL	2,000	435	570	-135
020IS	2,000	475	585	-110
032IS	3,200	610	765	-155
050IS	5,000	670	900	-230

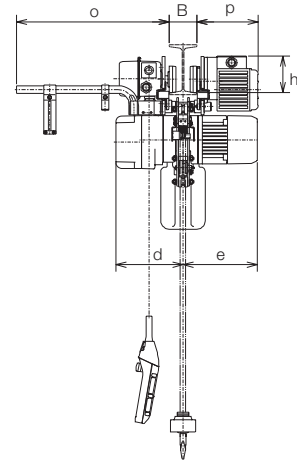
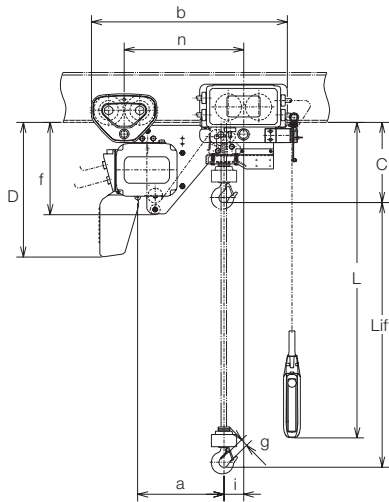

Motor trolley

Dimensions

Type	Load capacity	Dimensions (mm)																	
		D	E	a	b	d	c	f	g	h	i	j	k	K'	n	o	p	r	u
003IS-IS	250	430	3700	260	656 (616)	219	259	325	27	130	68	18	95	107	380	515	220	152 (56)	345 (249)
005IS-IS	500	525	3700	310	706 (666)	242	268	370	27	130	70	18	95	107	430	515	220	152 (56)	345 (249)
010IS-IS	1,000	550	3700	339	734 (694)	291	307	405	31	130	77	18	95	107	458	515	220	152 (56)	345 (249)
016IS-IS	1,600	640	3700	389	826 (803)	308	338	487	34	125	79	29	112	109	523	520	225	154 (69)	385 (300)
020IS-IS	2,000	840	3700	423	846 (823)	337	399	527	39	125	79	29	112	109	543	520	225	154 (69)	385 (300)
032IS-IS	3,200	830	3700	435	892 (884)	347	356	487	44	131	45	24	134	115	560	521	226	157 (79)	398 (320)
050IS-IS	5,000	860	4200	475	1057 (1057)	337	399	542	47	145	66	31	144	131	657	528	281	156 (53)	401 (297)

Please note: The numbers in the column „b“ stand for the manual trolley types. The numbers in „r“ and „u“ stand for plain trolleys. The numbers in column „D“ stand for a lifting height of 4 m. For further information please contact your local KITO dealer.

Technical data

Type	Load capacity	ER2								Weight
		Body size	Lifting motor		Lifting speed* (m/min)		Load chain diameter	Chain falls		
			Output, kW	Rating (% ED)	50 Hz					
SHER2M	kg				High	Low	mm		kg	
003IS-IS	250	B	0.56	40/20	Standard	10.8	1.8	4.3	1	313
003IS-IS	250	B	0.56	40/20	Adjustable	10.8	0.9	4.3	1	313
005IS-IS	500	C	0.9	40/20	Standard	8.5	1.4	6.0	1	625
005IS-IS	500	C	0.9	40/20	Adjustable	8.5	0.7	6.0	1	625
010IS-IS	1,000	D	1.8	40/20	Standard	8.2	1.4	7.7	1	1,250
010IS-IS	1,000	D	1.8	40/20	Adjustable	8.2	0.7	7.7	1	1,250
016IS-IS	1,600	E	1.8	40/20	Standard	5.3	0.9	10.2	1	2,000
016IS-IS	1,600	E	1.8	40/20	Adjustable	5.3	0.4	10.2	1	2,000
020IS-IS	2,000	F	3.5	40/20	Standard	6.6	1.1	11.2	1	2,500
020IS-IS	2,000	F	3.5	40/20	Adjustable	6.6	0.6	11.2	1	2,500
032IS-IS	3,200	E	3.5	40/20	Standard	4.1	0.7	10.2	2	4,000
032IS-IS	3,200	E	3.5	40/20	Adjustable	4.1	0.4	10.2	2	4,000
050IS-IS	5,000	F	3.5	40/20	Standard	3.3	0.6	11.2	2	6,250
050IS-IS	5,000	F	3.5	40/20	Adjustable	3.3	0.3	11.2	2	6,250

*Please note: The high speed is preset to the maximum speed at the KITO factory. The speeds are adjustable between High and Low. Just for straight beams. Curved beams and flange width on request. For further information please contact your local KITO dealer.

Type	Trolley								Weight, kg		
	Travel Motor		Travel speed			Flange width: B (mm)					
	SHER2M	Output, kW	Rating (% ED)		50 Hz		Standard	Option W30 (305 mm)	Motor trolley	Geared trolley	Plain trolley
High					Low						
003IS-IS	0.4	27/13	Standard	24	4	75 - 163	164 - 305	78	61	56	
003IS-IS	0.4	27/13	Adjustable	24	2.4	75 - 163	164 - 305	78	61	56	
005IS-IS	0.4	27/13	Standard	24	4	75 - 163	164 - 305	90	73	68	
005IS-IS	0.4	27/13	Adjustable	24	2.4	75 - 163	164 - 305	90	73	68	
010IS-IS	0.4	27/13	Standard	24	4	100 - 163	164 - 305	124	107	102	
010IS-IS	0.4	27/13	Adjustable	24	2.4	100 - 163	164 - 305	124	107	102	
016IS-IS	0.4	27/13	Standard	24	4	125 - 204	205 - 305	158	139	134	
016IS-IS	0.4	27/13	Adjustable	24	2.4	125 - 204	205 - 305	158	139	134	
020IS-IS	0.4	27/13	Standard	24	4	125 - 204	205 - 305	212	193	188	
020IS-IS	0.4	27/13	Adjustable	24	2.4	125 - 204	205 - 305	212	193	188	
032IS-IS	0.4	27/13	Standard	24	4	125 - 204	205 - 305	241	222	217	
032IS-IS	0.4	27/13	Adjustable	24	2.4	125 - 204	205 - 305	241	222	217	
050IS-IS	0.75	27/13	Standard	24	4	150 - 204	205 - 305	322	307	300	
050IS-IS	0.75	27/13	Adjustable	24	2.4	150 - 204	205 - 305	322	307	300	