



## VacuGiant

The VacuGiants are FEZER's heavy-duty lifters. They stand for highest carrying capacities, hardest operating conditions and the most robust design.

They can effortlessly and absolutely safely move the longest and widest sheets with weights of several tons.



VacuGiant VG .....	57/58
VacuGiant VG-90E .....	59/60
VacuGiant VG-180E .....	61/62
Application Examples .....	63/64

## Vacuum Load Lifting Devices

VacuGiant VG

### Horizontal Transport up to 40.000 kg

The lifter series VG brings movement into the heavy-duty area. The simple but very robust design and the intelligent safety features of these giants guarantee an absolutely safe and reliable handling of metal sheets with lengths of up to 30m, widths over 4 m and several tons of weight.

- Aluminum and steel mills
- Sheet commissioning
- Wind power plants
- Aeronautics
- Shipbuilding and dockyards
- Lorry superstructures

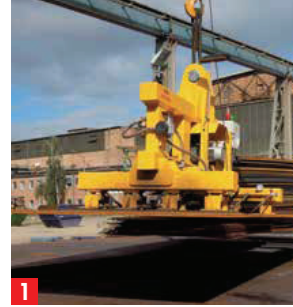
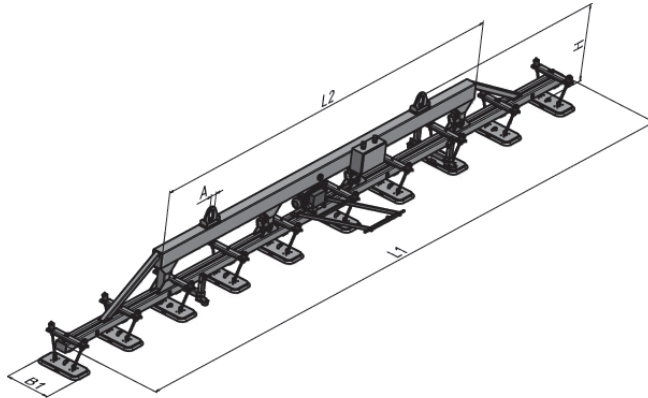

**FEZER**  
Simply move more.

Capacity (kg)	Type	Workpiece dimensions			Number of suction pads	Pump	L1 (m)	L2 (m)	B1 (m)	H (m)	A (mm)	Own weight (t)
		Length (m)	Width (m)	Thickness (mm)								
2.500	VG-	4 ... 20	0,5 ... 3	> 2	2 ... 6	016	3 ... 18	1 ... 10	0,9 ... 2,2	0,8 ... 1,4	120	0,4 ... 0,5
5.000	VG-	4 ... 20	0,5 ... 3	> 2	4 ... 10	025	3 ... 18	1 ... 10	0,9 ... 2,2	0,8 ... 1,4	120	0,7 ... 0,8
7.500	VG-	4 ... 20	0,5 ... 3	> 2	6 ... 12	040	3 ... 18	1 ... 10	0,9 ... 2,2	0,8 ... 1,4	120	1,0 ... 1,2
10.000	VG-	4 ... 20	0,5 ... 3	> 2	8 ... 16	040	3 ... 18	1 ... 10	0,9 ... 2,2	0,8 ... 1,4	120	1,4 ... 1,6
15.000	VG-	8 ... 30	1,0 ... 4,5	> 3	12 ... 24	063	6 ... 26	6 ... 16	0,9 ... 3,4	1,2 ... 2,6	160	2,0 ... 2,6
20.000	VG-	8 ... 30	1,0 ... 4,5	> 3	16 ... 32	063	6 ... 26	6 ... 16	0,9 ... 3,4	1,2 ... 2,6	160	2,6 ... 3,2
25.000	VG-	8 ... 30	1,0 ... 4,5	> 3	20 ... 40	0100	6 ... 26	6 ... 16	0,9 ... 3,4	1,2 ... 2,6	160	3,2 ... 3,8
30.000	VG-	8 ... 30	1,0 ... 4,5	> 3	24 ... 48	0100	6 ... 26	6 ... 16	0,9 ... 3,4	1,2 ... 2,6	160	3,8 ... 4,4
35.000	VG-	8 ... 30	1,0 ... 4,5	> 3	28 ... 56	0160	6 ... 26	6 ... 16	0,9 ... 3,4	1,2 ... 2,6	160	4,4 ... 5,0
40.000	VG-	8 ... 30	1,0 ... 4,5	> 3	32 ... 64	0160	6 ... 26	6 ... 16	0,9 ... 3,4	1,2 ... 2,6	160	5,0 ... 5,6

### VacuGiant VG in Action

- 1 Handling 8.000 kg steel sheets
- 2 VacuGiant for transporting aluminum blocks up to 4.000 kg
- 3 Lifting large-size steel sheets with a weight of up to 12.000 kg
- 4 Handling aluminum plates with a length of 12 m and a weight of up to 8.000 kg

## Vacuum Load Lifting Devices

VacuGiant VG-90E

### Swivelling Design up to 15.000 kg

In many areas heavy loads must be set upright or taken out of upright storage. For these applications the lifter series VG-90E is available with a swivel feature. Usually hydraulic linear drives, secured by non-return valves, swivel the load. This allows to stop the workpieces at any point.

- Commissioning of steel sheets
- Aeronautics
- Shipbuilding and dockyards
- Lorry superstructures

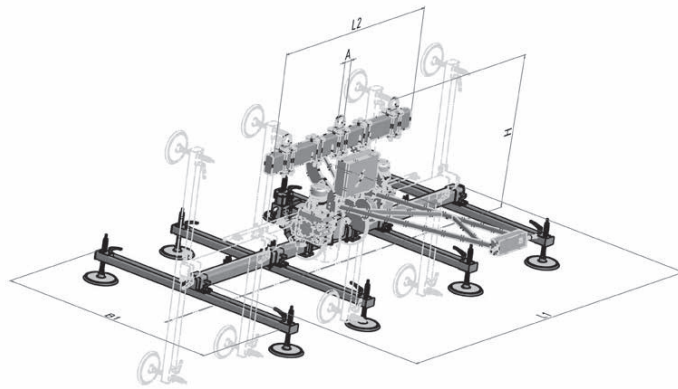

Capacity (kg)	Type	Workpiece dimensions			Number of suct. pads	Pump	Swivel drive	L1 (m)	L2 (m)	B1 (m)	H (m)	A (mm)	Own weight (t)
		Length (m)	Width (m)	Thickness (mm)									
2.500	VG90-	4 ... 20	0,5 ... 3	> 2	4 ... 24	025	hydr.	3 ... 18	1 ... 12	0,9 ... 2,2	1 ... 1,8	120	0,8 ... 1,2
5.000	VG90-	4 ... 20	0,5 ... 3	> 2	8 ... 36	025	hydr.	3 ... 18	1 ... 12	0,9 ... 2,2	1 ... 1,8	120	1,2 ... 1,6
7.500	VG90-	4 ... 20	0,5 ... 3	> 2	12 ... 48	040	hydr.	3 ... 18	1 ... 12	0,9 ... 2,2	1 ... 1,8	120	1,6 ... 2,0
10.000	VG90-	6 ... 20	1 ... 3	> 3	16 ... 48	040	hydr.	4 ... 18	1 ... 12	0,9 ... 2,2	1 ... 2,4	160	2,0 ... 2,4
12.500	VG90-	6 ... 20	1 ... 3	> 3	20 ... 48	063	hydr.	4 ... 18	1 ... 12	0,9 ... 2,2	1 ... 2,4	160	2,4 ... 2,8
15.000	VG90-	6 ... 20	1 ... 3	> 3	24 ... 48	063	hydr.	4 ... 18	1 ... 12	0,9 ... 2,2	1 ... 2,4	160	2,8 ... 3,6

### VacuGiant VG-90E in Action

- 1 Both-sided swivelling VacuGiant for 16 m long side panels weighing 2.000 kg
- 2 Swivelling VacuGiant with load compensation adjustment for handling plane calottes
- 3 Handling sandwich elements weighing 2.500 kg
- 4 VacuGiant in extremely flat design for vertical storage of 8.000 kg steel sheets

## Vacuum Load Lifting Devices

VacuGiant VG-180E

### Turnable Design up to 2.500 kg

In some cases heavy loads need to be turned over. The right choice for this is the lifter series VG-180E. The robust design and the large-dimensioned safety tanks guarantee an adequate and calming safety when turning over those heavy loads. The operation is carried out by powerful gear motors with brakes and automatic end position arrest

- Aeronautics
- Shipbuilding and dockyards
- Lorry side and roof elements
- Plastic manufacture

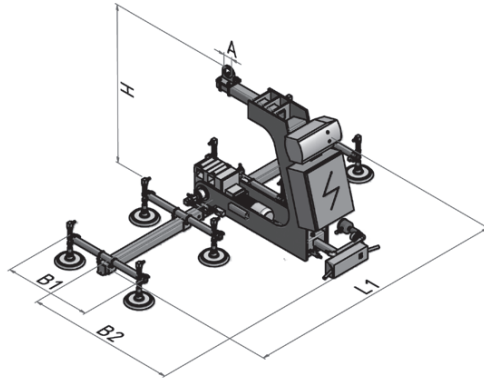

Capacity (kg)	Type	Workpiece dimensions			Number of suct. pads	Pump	Turning drive	L1 (m)	B1 (m)	B2 (m)	H (m)	A (mm)	Own weight (t)
		Length (m)	Width (m)	Thickn. (mm)									
1.000	VG90-	4 ... 20	0,5 ... 3	> 2	4 ... 24	025	electr.	2 ... 18	0,5 ... 2	1 ... 2,5	1 ... 2,5	120	0,6 ... 0,8
1.500	VG90-	4 ... 20	0,5 ... 3	> 2	8 ... 36	025	electr.	2 ... 18	0,5 ... 2	1 ... 2,5	1 ... 2,5	120	0,8 ... 1,0
2.000	VG90-	4 ... 20	0,5 ... 3	> 2	12 ... 48	040	electr.	2 ... 18	0,5 ... 2	1 ... 2,5	1 ... 2,5	120	1,0 ... 1,2
2.500	VG90-	4 ... 20	0,5 ... 3	> 2	16 ... 48	040	electr.	2 ... 18	0,5 ... 2	1 ... 2,5	1 ... 2,5	120	1,2 ... 1,4

### VacuGiant VG-180E in Action

- 1 Extendable VacuGiant for turning over 16 m long carbon wings with a weight of 1.000 kg
- 2 VacuGiant for turning over 12 m long special plastic plates up to 750 kg

## VacuGiant VG

### Application Examples

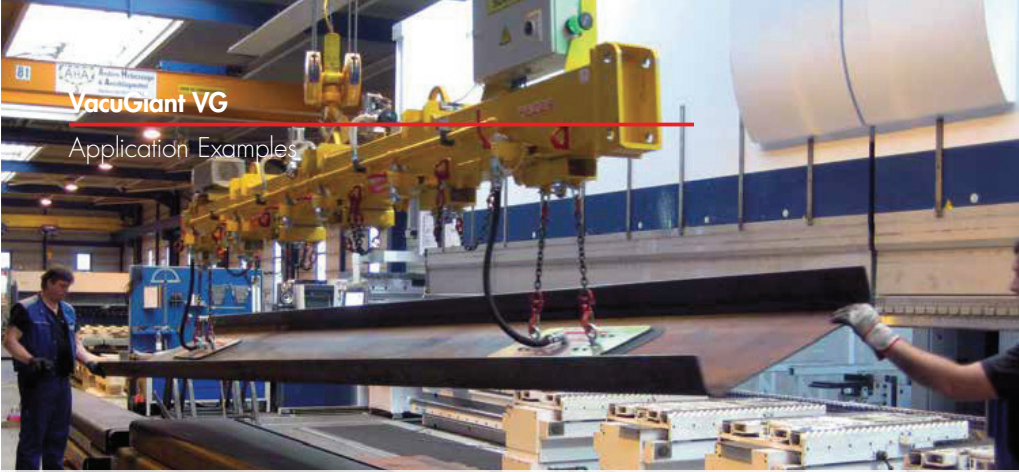

VacuGiant on a bending machine with chain suspension



VacuGiant with 12.000 kg carrying capacity and electrically extendable main beam from 8 to 12 m



Transport of 36 m long aluminum sheets weighing 4.500 kg for the manufacture of wing parts for the Airbus A380

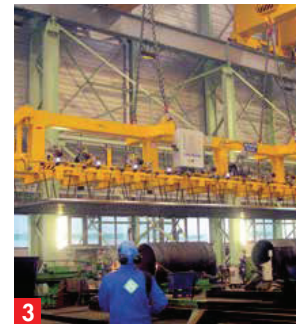

**FEZER**  
Simply move more.

### VacuGiant in Action

- 1 VacuGiant with forklift truck attachment and carrying capacity of 5.000 kg
- 2 Combination lifter for the transport of steel sheets which are formed to tubes
- 3 VacuGiant for the transport of steel sheets with a weight of up to 40.000 kg
- 4 Outdoor operation of a VacuGiant with self-sufficient pump for transporting concrete plates