



**Safe and  
synchronous  
lifting**

# TWER2M Twin Hook electric chain hoist

- ▶ Up to 5,000 kg load capacity
- ▶ 380 - 440 V / 50 Hz
- ▶ 24 V control voltage
- ▶ Frequency inverter for precise positioning of the load
- ▶ Single and dual lifting and traveling speed
- ▶ Operating hours counter / load cycle counter
- ▶ Range limit switch for lifting / lowering
- ▶ Thermal motor protection
- ▶ Electromagnetic brake
- ▶ Nickel-plated load chain grade T, series DAT (G80) in accordance with standard EN 818-7
- ▶ Steel chain container

## Options

- ▶ Fall protection device and bumpers
- ▶ Limit Lock - Individual programmable hook position limits (page 42 – 43)
- ▶ Stepless Speed - Infinitely variable speed control (page 45 – 45)



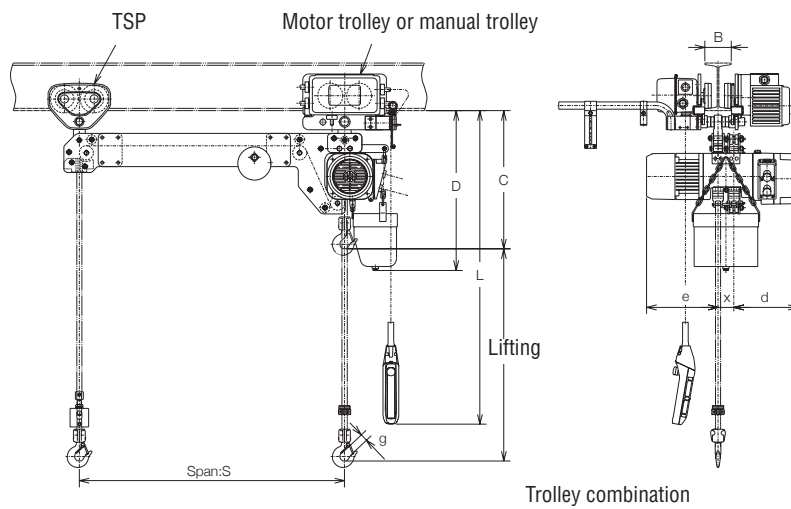
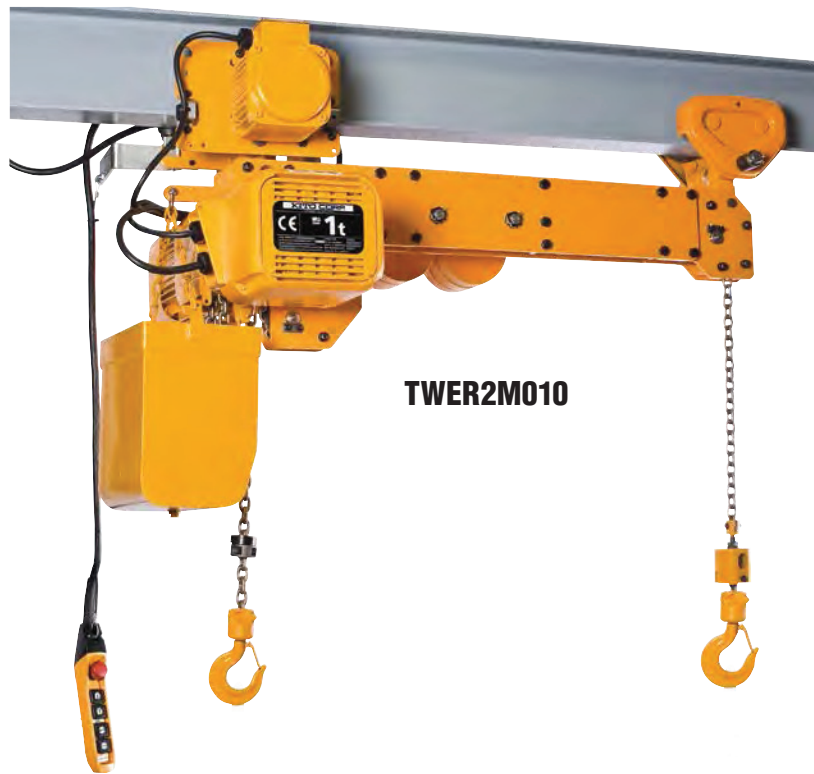

## Dimensions

Type	Load capacity kg	Headroom C	Dimensions (mm)					
			D	S	d	e	g	x
003IS-IS	125 + 125	535	620	max. 4,000	300	271	27	60
005IS-IS	250 + 250	535	620	max. 4,000	300	268	27	60
010IS-IS	500 + 500	615	710	max. 4,000	493	307	31	71
020IS-IS	1,000 + 1,000	790	790	max. 4,000	600	363	39	81
032IS-IS	1,600 + 1,600	820	820	max. 4,000	600	363	44	81
050IS-IS	2,500 + 2,500	990	990	max. 4,000	611	418	46	85

## Technical data

Type	Load capacity	Body size	ER2							Weight
			Lifting motor		Lifting speed* (m/min)	Load chain diameter	Chain falls			
			Output, kW	Rating (% ED)				50 Hz		
TWER2M	kg						High	Low	mm	
003IS-IS	125 + 125	C	0.56	40/20	Standard	10.8	1.8	6.0	2	120
005IS-IS	250 + 250	C	0.9	40/20	Standard	8.5	1.4	6.0	2	125
010IS-IS	500 + 500	D	1.8	40/20	Standard	8.2	1.4	7.7	2	180
020IS-IS	1,000 + 1,000	E	3.5	40/20	Standard	8.2	1.4	10.2	2	265
032IS-IS	1,600 + 1,600	E	3.5	40/20	Standard	5.2	0.9	10.2	4	310
050IS-IS	2,500 + 2,500	F	3.5	40/20	Standard	3.3	0.6	11.2	4	365

Type	Load capacity	Body size	Trolley						
			Travel Motor		Travel speed* (m/min)	Flange width: B (mm)			
			Output, kW	Rating (% ED)		50 Hz		Option W30 (305 mm)	
TWER2M	kg						High		Low
003IS-IS	125 + 125	C	0.4	27/13	Standard	24	4	58 - 153	164 - 305
005IS-IS	250 + 250	C	0.4	27/13	Standard	24	4	58 - 153	164 - 305
010IS-IS	500 + 500	D	0.4	27/13	Standard	24	4	58 - 153	164 - 305
020IS-IS	1,000 + 1,000	E	0.4	27/13	Standard	24	4	82 - 204	204 - 305
032IS-IS	1,600 + 1,600	E	0.4	27/13	Standard	24	4	100 - 204	204 - 305
050IS-IS	2,500 + 2,500	F	0.75	27/13	Adjustable	24	2.4	100 - 204	204 - 305

\*Please note: The high speed is preset to the maximum speed at the KITO factory. The speeds are adjustable between High and Low.  
Just for straight beams. Curved beams on request. The exact net weight depends on the hook space. The maximum lifting height is 8 m.  
Special lifting heights on request. For further information please contact your local KITO dealer.