

By CARPEL[®]  srl

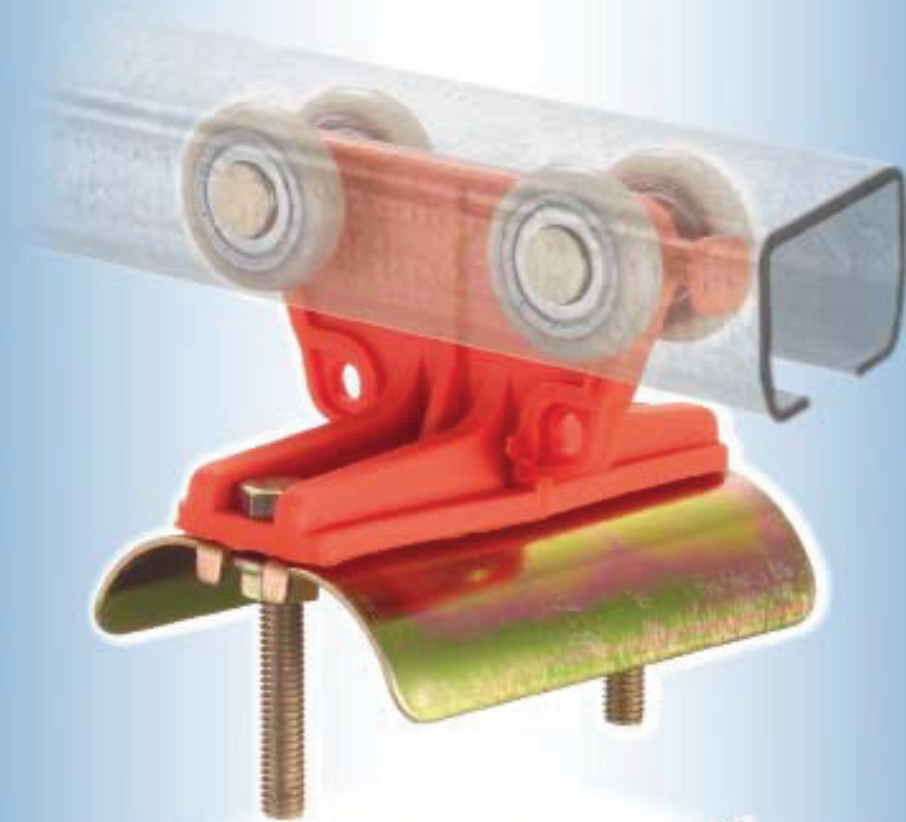

LINEA PORTACAVI “TIPO EUROPEO” CABLE CARRYING LINE “EUROPEAN” TYPE

La linea portacavi tipo EUROPEO è un sistema pratico, efficiente e sicuro per la distribuzione dell'energia, sia essa elettrica, pneumatica o altro, per apparecchi mobili quali gru, carri ponti etc.

In questo catalogo troverete sicuramente la soluzione più adatta al vostro problema potendo scegliere tra più linee di carrelli portacavi tutti normalizzati per scorrere in maniera sicura, efficiente e duratura all'interno della canalina di nostra produzione. Qualunque sia la scelta da voi operata, sarà una scelta di qualità e sicurezza in quanto su tutte le linee troverete apposto il marchio "CE" a garanzia che i nostri prodotti rispondono ai requisiti dettati dalla Direttiva Macchine 89/932 CEE e successivi emendamenti.

The cable carrying line "EUROPEAN" type is a handy, efficient and safe system for electrical, pneumatic and other energy distribution to mobile equipment such as cranes, overhead traveling cranes, etc.

This catalogue includes various cable carrying lines; among them you will surely find the most suitable to your requirements. You may choose among several lines of cable carrying trolleys, all of them being standardized for assuring a safe, efficient and lasting sliding operation inside our cable raceway. Regardless of your choice, it will assure you quality and safety; all our lines have been labelled with the "CE" mark, to guarantee that our products meet the 89/932/EEC Machinery Directive and further amendments.



Ci riserviamo la facoltà di apportare, senza alcun preavviso, modifiche costruttive al fine di migliorare le qualità tecniche, funzionali ed estetiche del prodotto.

We reserve the right to make modifications in order to improve the technical, functional and aesthetical qualities of our products without any prior notice.



AZIENDA CON SISTEMA QUALITÀ
CERTIFICATO DA DNV
=UNI EN ISO 9001/2000=

LINEA PORTACAVI "TIPO EUROPEO"
CABLE CARRYING LINE "EUROPEAN TYPE"



Canalina Portacavo
Cable carrying raceway

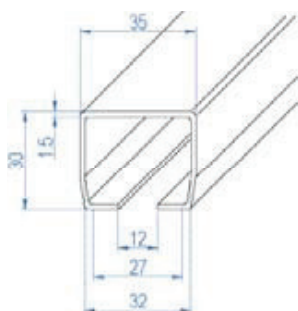

Materiale/ Material	Acciaio zincato/ Galvanized Steel
Spessore/ Thickness	1,5 mm
Momento d'inerzia/ Moment of inertia	1,9 cm ⁴
Momento resistente/ Resisting moment	1,1 cm ³
Peso/ Weight	1,19 kg/m
Distanza sospensioni/ Suspension distance	1,5 m
Portata/ Capacity	30 kg ogni/ every 1,5 m

Articolo/ Item	1
Codice barre/ Bar code 3	CAN 1 EUR 3
Codice barre/ Bar code 4	CAN 1 EUR 4
Codice barre/ Bar code 5	CAN 1 EUR 5
Codice barre/ Bar code 6	CAN 1 EUR 6

Testata semplice in nylon
Nylon simple head



Materiale/ Material	Corpo in nylon/ Nylon body
	Minuteria in acciaio zincato/ Small parts in galvanized steel
Peso/ Weight	65 g

Articolo/ Item	5
Codice/ Code	TS 1 SEMPN

Testata semplice in acciaio
Steel simple head

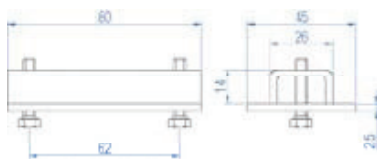
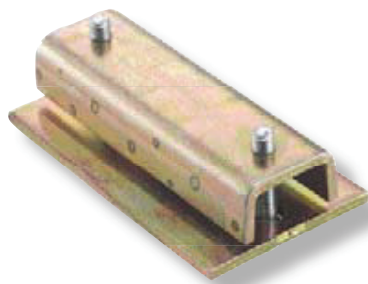

Materiale/ Material	Acciaio zincato/ Galvanized Steel
Peso/ Weight	175 g

Articolo/ Item	5
Codice/ Code	TS 1 Sempa

LINEA PORTACAVI "TIPO EUROPEO"
CABLE CARRYING LINE "EUROPEAN TYPE"



Sospensione con fissaggio laterale
Suspension with side fixing

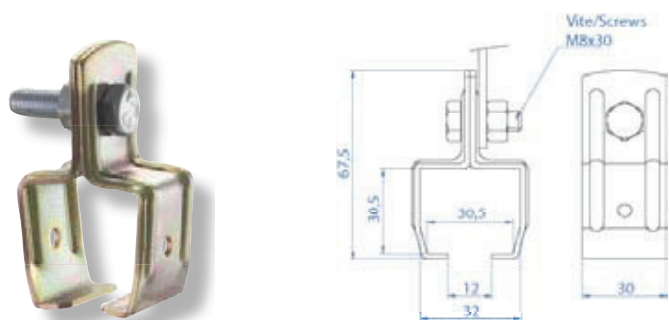

Materiale/Material	Acciaio zincato/Galvanized Steel	
	con viti with screws	senza viti without screws
Peso/Weight	100 g	80 g
Portata/Capacity	30 kg	30 kg

Articolo/Item	3	4
Codice/Code	SOS 1 FLCV	SOS 1 FLSV

Sospensione con fissaggio a parete
Suspension with wall fixing

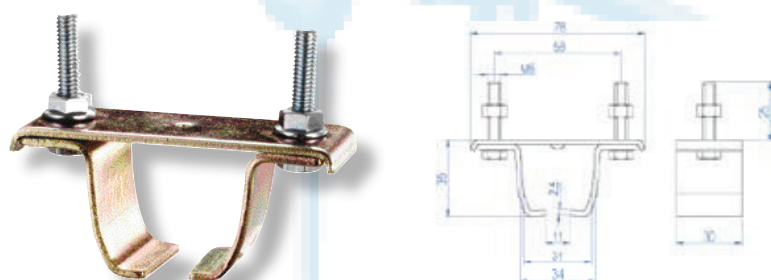

Materiale/Material	Acciaio zincato/Galvanized Steel	
	con viti with screws	senza viti without screws
Peso/Weight	125 g	100 g
Portata/Capacity	45 kg	45 kg

Articolo/Item	4+4	4+4
Codice/Code	SOS 1 PACV	SOS 1 PASV

Sospensione a parete con fissaggio di tipo composto
Wall suspension with built-up fixing system

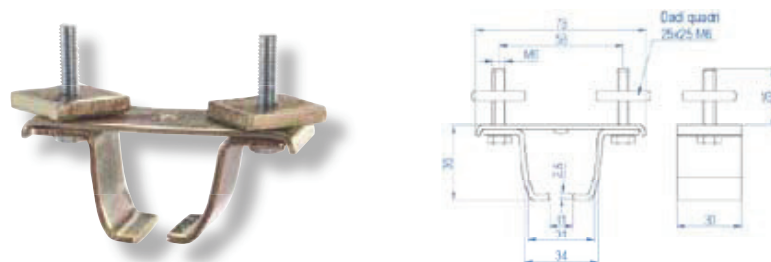

Materiale/Material	Acciaio zincato/Galvanized Steel	
Peso/Weight	150 g	
Portata/Capacity	45 kg	

Articolo/Item	4+4/C
Codice/Code	SOS 1 PATC

Giunto doppio in acciaio
Double steel joint

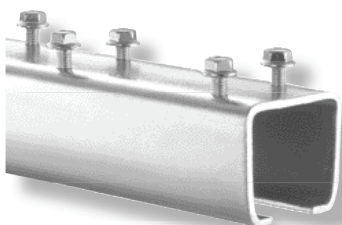

Materiale/ <i>Material</i>	Acciaio zincato/ <i>Galvanized Steel</i>
Peso/ <i>Weight</i>	485 g

Articolo/ <i>Item</i>	2 bis
Codice/ <i>Code</i>	GIU 1 FD

Giunto semplice in acciaio
Simple steel joint

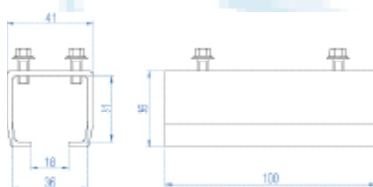
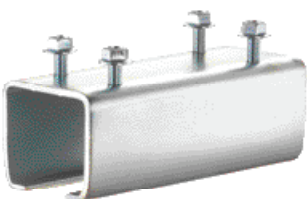

Materiale/ <i>Material</i>	Acciaio zincato/ <i>Galvanized Steel</i>
Peso/ <i>Weight</i>	235 g

Articolo/ <i>Item</i>	2
Codice/ <i>Code</i>	GIU 1 FS

Giunto semplice in nylon
Simple nylon joint

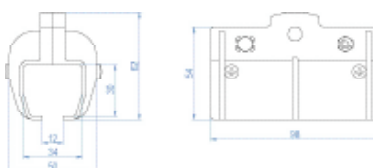

Materiale/ <i>Material</i>	Nylon
Peso/ <i>Weight</i>	90 g

Articolo/ <i>Item</i>	2
Codice/ <i>Code</i>	GIU 1 NY

LINEA PORTACAVI "TIPO EUROPEO" CABLE CARRYING LINE "EUROPEAN TYPE"



Testata con sella Head with saddle

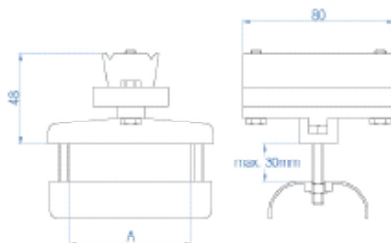

Materiale/Material	Corpo in nylon/Nylon body Acciaio zincato/Galvanized steel
Portata/Capacity	25 kg

Sella/Saddle	Peso/Weight	Codice/Code	Articolo/Item
A= 35 mm	155 g	TSN1P35	6
A= 50 mm	165 g	TSN1P50	7
A= 65 mm	175 g	TSN1P65	8

Carrello portacavi Cable carrying trolley

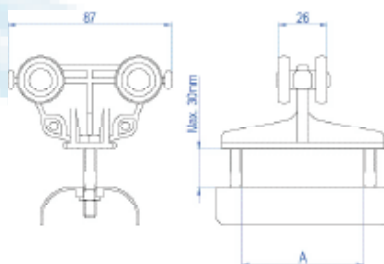

Materiale/Material	Corpo in nylon/Nylon body Acciaio zincato/Galvanized steel
--------------------	---

Ruote Nylon/Nylon Wheels	Ø 25 mm
Portata/Capacity	15 kg

Sella/Saddle	Peso/Weight	Codice/Code	Articolo/Item
A= 35 mm	115 g	CRN1P35N	9
A= 50 mm	125 g	CRN1P50N	10
A= 65 mm	145 g	CRN1P65N	11

Cuscinetti rivestiti in nylon/Nylon coated bearing	Ø 25 mm
Portata/Capacity	20 kg

Sella/Saddle	Peso/Weight	Codice/Code	Articolo/Item
A= 35 mm	135 g	CRN1P35C	12
A= 50 mm	145 g	CRN1P50C	13
A= 65 mm	165 g	CRN1P65C	14

Traino Trailer

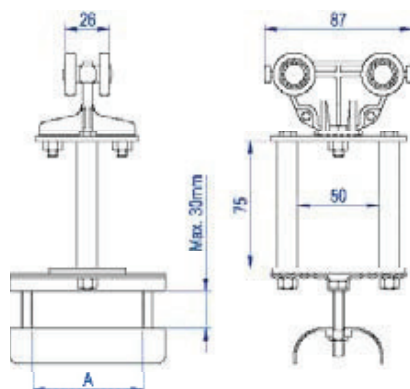

Materiale/Material	Corpo in nylon/Nylon body Acciaio zincato/Galvanized steel
--------------------	---

Ruote Nylon/Nylon Wheels	Ø 25 mm
Portata/Capacity	10 kg

Sella/Saddle	Peso/Weight	Codice/Code	Articolo/Item
A= 35 mm	130 g	TRN1P35N	15
A= 50 mm	140 g	TRN1P50N	16
A= 65 mm	160 g	TRN1P65N	17

Cuscinetti rivestiti in nylon/Nylon coated bearing	Ø 25 mm
Portata/Capacity	15 kg

Sella/Saddle	Peso/Weight	Codice/Code	Articolo/Item
A= 35 mm	165 g	TRN1P35C	18
A= 50 mm	170 g	TRN1P50C	19
A= 65 mm	190 g	TRN1P65C	20

LINEA PORTACAVI "TIPO EUROPEO" CABLE CARRYING LINE "EUROPEAN TYPE"



Testata con sella Head with saddle

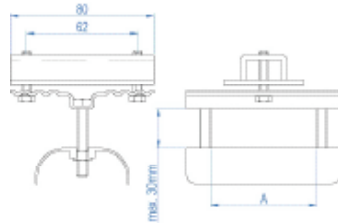

Materiale/Material	Acciaio zincato/Galvanized Steel
Portata/Capacity	35 kg

Sella/Saddle	Peso/Weight	Codice/Code	Articolo/Item
A= 25 mm	265 g	TSA 1 P25	60
A= 35 mm	285 g	TSA 1 P35	61
A= 55 mm	320 g	TSA 1 P55	62
A= 65 mm	340 g	TSA 1 P65	63
A= 80 mm	365 g	TSA 1 P80	64
A= 100 mm	400 g	TSA 1 P10	65

Carrello portacavi Cable carrying trolley

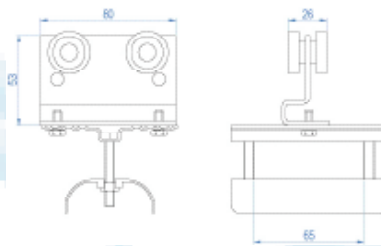

Materiale/Material	Acciaio zincato/Galvanized Steel
Ruote/Wheels	Cuscinetti acciaio/Steel coated bearings Ø 25 mm
Portata/Capacity	30 kg

Sella/Saddle	Peso/Weight	Codice/Code	Articolo/Item
A= 25 mm	310 g	CRA 1 P25C	66
A= 35 mm	330 g	CRA 1 P35C	67
A= 55 mm	365 g	CRA 1 P55C	68
A= 65 mm	385 g	CRA 1 P65C	69
A= 80 mm	410 g	CRA 1 P80C	70
A= 100 mm	445 g	CRA 1 P10C	71

Traino Trailer

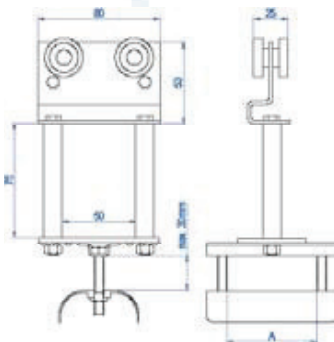

Materiale/Material	Acciaio zincato/Galvanized Steel
Ruote/Wheels	Cuscinetti acciaio/Steel coated bearings Ø 25 mm
Portata/Capacity	25 kg

Sella/Saddle	Peso/Weight	Codice/Code	Articolo/Item
A= 25 mm	485 g	TRA 1 P25C	72
A= 35 mm	505 g	TRA 1 P35C	73
A= 55 mm	540 g	TRA 1 P55C	74
A= 65 mm	560 g	TRA 1 P65C	75
A= 80 mm	585 g	TRA 1 P80C	76
A= 100 mm	620 g	TRA 1 P10C	77

Carrello portacavi - due pezzi Two-piece cable carrying trolley

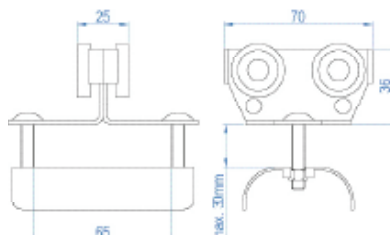
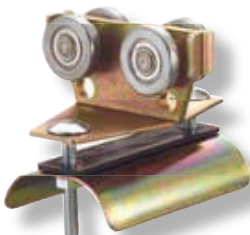

Materiale/Material	Acciaio zincato/Galvanized Steel
Ruote/Wheels	Cuscinetti acciaio/Steel coated bearings Ø 25 mm
Portata/Capacity	20 kg

Sella/Saddle	Peso/Weight	Codice/Code	Articolo/Item
A= 65 mm	260 g	CRD 1 P65C	69 bis

Testata sella girevole
Head with slewing saddle

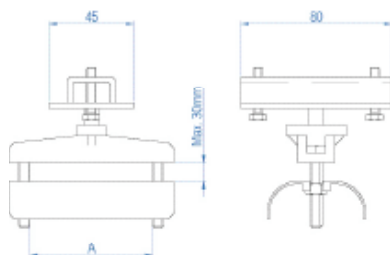
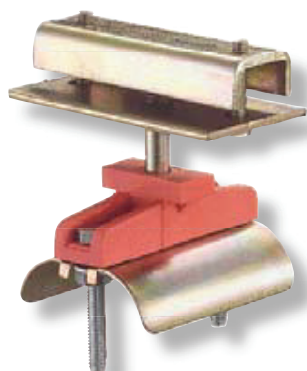

Materiale/Material	Acciaio zincato/Galvanized Steel
Portata/Capacity	25 kg

Sella/Saddle	Peso/Weight	Codice/Code	Articolo/Item
A= 35 mm	210 g	TSA1P35SG	61-G
A= 50 mm	275 g	TSA1P55SG	62-G
A= 65 mm	295 g	TSA1P65SG	63-G

Carrello sella girevole
Trolley with slewing saddle

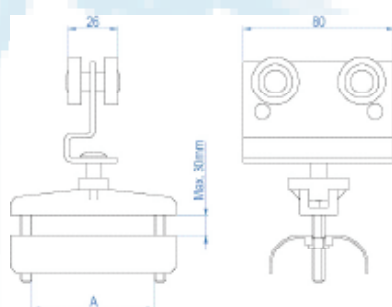

Materiale/Material	Acciaio zincato/Galvanized Steel
Ruote/Wheels	Cuscinetti acciaio/Steel coated bearings Ø 25 mm
Portata/Capacity	20 kg

Sella/Saddle	Peso/Weight	Codice/Code	Articolo/Item
A= 35 mm	385 g	CRA1P35SG	67-G
A= 50 mm	320 g	CRA1P55SG	68-G
A= 65 mm	340 g	CRA1P65SG	69-G

Traino sella girevole
Trailer with slewing saddle

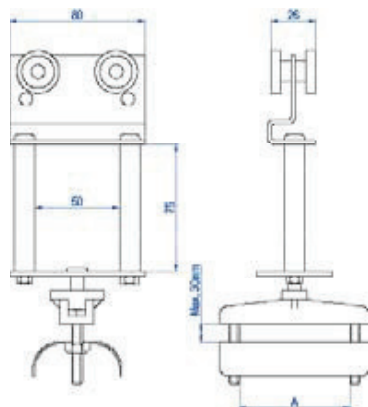

Materiale/Material	Acciaio zincato/Galvanized Steel
Ruote/Wheels	Cuscinetti acciaio/Steel coated bearings Ø 25 mm
Portata/Capacity	15 kg

Sella/Saddle	Peso/Weight	Codice/Code	Articolo/Item
A= 35 mm	450 g	TRA1P35SG	73-G
A= 50 mm	495 g	TRA1P55SG	74-G
A= 65 mm	515 g	TRA1P65SG	75-G

Testata con morsetto
Head with clamp

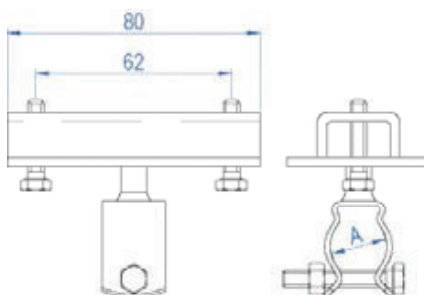
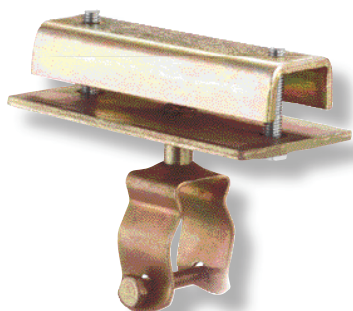

Materiale/Material	Acciaio zincato/Galvanized Steel
Portata/Capacity	30 kg
A (Ø max cavo/Cable max)	22 mm
Peso/Weight	205 g

Articolo/Item	42
Codice/Code	TSN 1 M22

Carrello con morsetto
Trolley with clamp

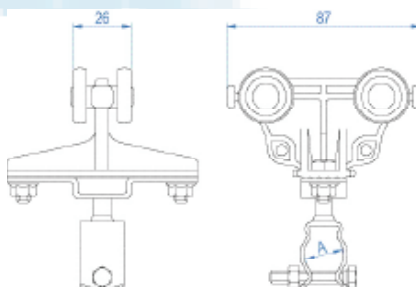

Materiale/Material	Corpo in nylon/Nylon body
Minuterie in acciaio zincato/Small parts in galvanized steel	
Ruote/Wheels	Nylon Ø 25 mm
Cuscinetti rivestiti nylon/Nylon coated bearings Ø 25 mm	
Portata/Capacity	20 kg
A (Ø max cavo/Cable max)	22 mm

	Ruote nylon	Ruote cuscinetto
	Nylon wheels	Wheels with bearing
Peso/Weight	130 g	150 g

Articolo/Item	45	46
Codice/Code	CRN 1 M22N	CRN 1 M22C

Traino con morsetto
Trailer with clamp

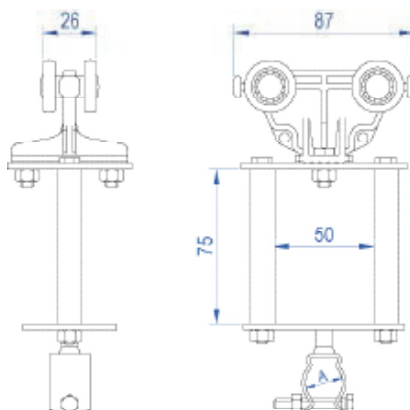

Materiale/Material	Corpo in nylon/Nylon body
Minuterie in acciaio zincato/Small parts in galvanized steel	
Ruote/Wheels	Nylon Ø 25 mm
Cuscinetti rivestiti nylon/Nylon coated bearings Ø 25 mm	
A (Ø max cavo/Cable max)	22 mm

	Ruote nylon	Ruote cuscinetto
	Nylon wheels	Wheels with bearing
Peso/Weight	390 g	415 g
Portata/Capacity	15 kg	20 kg

Articolo/Item	47	48
Codice/Code	TRN 1 M22N	TRN 1 M22C

Connettore per cavo piatto - presa tipo CARPEL
Connector for flat cable - socket type CARPEL

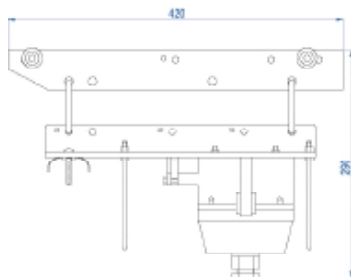
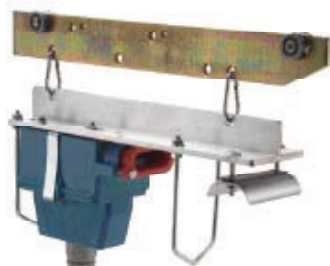

Materiale/ Material	Piastra in alluminio/ Aluminium plate		
	Presa in nylon/ Nylon socket		
	Stecca in acciaio zincato/ Galvanized steel slat		
	Minuteria in acciaio zincato/ Small parts in galvanized steel		
Ruote/ Wheels	Cuscinetti acciaio/ Steel coated bearings Ø 25 mm		
Portata/ Capacity	35 kg		
Peso/ Weight	2900 g		

Articolo/Item	015	030	040
Codice/Code	CON 1 P10	CON 1 P16	CON 1 P24
	10 Poli/Pole	16 Poli/Pole	24 Poli/Pole

Connettore per cavo piatto - presa tipo STANDARD
Connector for flat cable - socket type STANDARD

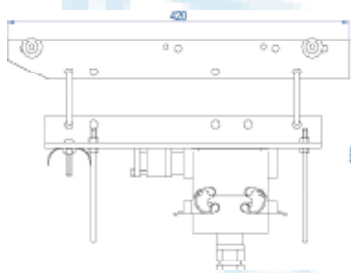

Materiale/ Material	Piastra in alluminio/ Aluminium plate		
	Presa in alluminio/ Aluminium socket		
	Stecca in acciaio zincato/ Galvanized steel slat		
	Minuteria in acciaio zincato/ Small parts in galvanized steel		
Ruote/ Wheels	Cuscinetti acciaio/ Steel coated bearings Ø 25 mm		
Portata/ Capacity	35 kg		
Peso/ Weight	2660 g		

Articolo/Item	026	027	028	029
Codice/Code	CON 1 P10I	CON 1 P16I	CON 1 P24I	CON 1 P32I
	10 Poli/Pole	16 Poli/Pole	24 Poli/Pole	32 Poli/Pole

Connettore per cavo tondo - presa tipo STANDARD
Connector for round cable - socket type STANDARD

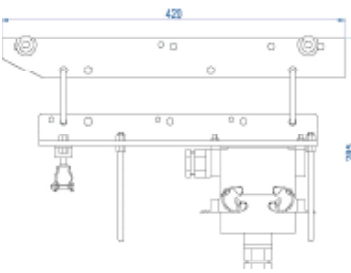

Materiale/ Material	Piastra in alluminio/ Aluminium plate		
	Presa in alluminio/ Aluminium socket		
	Stecca in acciaio zincato/ Galvanized steel slat		
	Minuteria in acciaio zincato/ Small parts in galvanized steel		
Ruote/ Wheels	Cuscinetti acciaio/ Steel coated bearings Ø 25 mm		
Portata/ Capacity	35 kg		
Peso/ Weight	2885 g		

Articolo/Item	005	010	020	025
Codice/Code	CON 1 T10	CON 1 T16	CON 1 T24	CON 1 T32
	10 Poli/Pole	16 Poli/Pole	24 Poli/Pole	32 Poli/Pole

Traino speciale
Special trailer

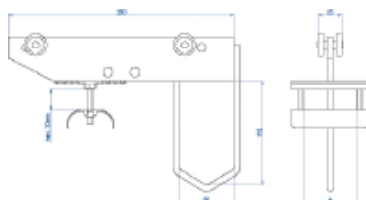

Materiale/Material	Acciaio zincato/Galvanized Steel
Ruote/Wheels	Cuscinetti acciaio/Steel coated bearings Ø 25 mm
Portata/Capacity	30 kg

Sella/Saddle	Peso/Weight	Codice/Code	Articolo/Item
A= 25 mm	270 g	TRA 1 S25C	001
A= 35 mm	330 g	TRA 1 S35C	002
A= 55 mm	345 g	TRA 1 S55C	003
A= 65 mm	370 g	TRA 1 S65C	004
A= 80 mm	395 g	TRA 1 S80C	006
A= 100 mm	430 g	TRA 1 S10C	007

Traino a stecca
Slat trailer

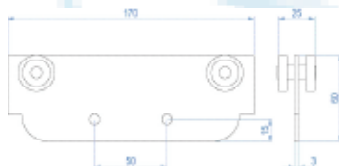

Materiale/Material	Acciaio zincato/Galvanized Steel
Ruote/Wheel	Cuscinetti acciaio/Steel coated bearings Ø 25 mm
Portata/Capacity	30 kg
Peso/Weight	270 g

Articolo/Item	170
Codice/Code	TRA 1 STEC

Griffa portacavi
Cable carrying claw

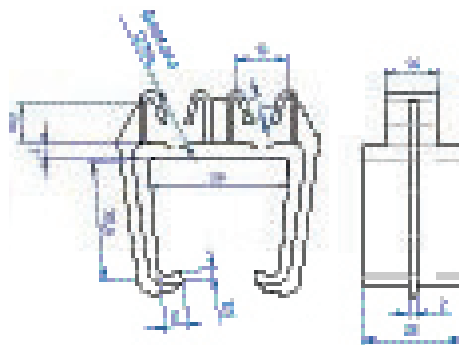

Materiale/Material	Nylon
Peso/Weight	15 g

Articolo/Item	4201
Codice/Code	GRIFFA/EUR



ISTRUZIONI DI MONTAGGIO - linea con traino -

ASSEMBLY INSTRUCTIONS - line with trailer -

- 1- Posizionare le sospensioni nelle proprie sedi (pareti o mensole); in questa fase di montaggio non bisogna stringere eccessivamente le viti delle sospensioni, in modo da permettere l'inserimento delle barre di canalina ed il loro eventuale posizionamento.
- 2- Inserire le barre di canalina nelle sospensioni; verificare la presenza di un numero adeguato di sospensioni su tutta la linea.
In questa fase è necessario prestare particolare attenzione allo "spigolo vivo" del taglio della canalina: tale spigolo è necessario per un corretto allineamento delle parti di canalina da unire e per far scorrere correttamente il carrello all'interno.
- 3- Applicare i giunti alle estremità delle barre, quindi serrare le viti senza deformare la canalina. Le estremità delle canaline devono essere adiacenti e ben allineate (la conformazione del giunto impedisce il non allineamento delle canaline) onde evitare che il carrello durante la corsa urti contro l'estremità della canalina e che, con il passare del tempo, sia pregiudicato il buon funzionamento del carrello stesso.
- 4- Serrare tutte le viti delle sospensioni verificando nel medesimo tempo il bloccaggio dell'intera linea.
- 5- Verificare l'allineamento dell'intera linea.
- 6- Inserire la prima testata (senza sella) e fissarla all'estremità opposta a quella in cui la linea si allaccerà all'alimentazione.
- 7- Inserire il traino nella canalina nell'estremità senza testata.
- 8- Di seguito, nello stesso modo, inserire tutti i carrelli che sosterranno il cavo di alimentazione
- 9- Posizionare la testata rimanente (con sella) e fissarla in modo da chiudere la linea. La chiusura della linea impedisce la fuoriuscita del traino e dei carrelli.
- 10- Inserire il cavo conduttore nel carrello, tra sella e controsella, partendo dalla testata con la sella sino ad arrivare al traino.
- 11- Stringere le viti del carrello, fissando il cavo tra sella e controsella, avendo cura di verificare che non sia presente alcun movimento di scorrimento del cavo nel carrello.
- 12- Lasciare tra carrello e carrello una quantità di cavo pari all'ansa desiderata.

- 1- Place the suspensions into their seats (walls or brackets), without overtightening the suspension screws so as to allow the raceway bars to be inserted and positioned, if necessary.*
- 2- Insert the raceway bars into the suspensions; be sure that a proper number of suspensions are all over the line.
In this phase particular attention has to be paid to the "sharp edge" of the raceway cutting side: such an edge is required to properly align the raceway parts to be connected and for the trolley to properly slide inside.*
- 3- Apply the joints to the bar ends, then tighten the screws without deforming the raceway. The raceway ends must be adjacent and well aligned (the joint configuration avoids the raceway misalignment) preventing the trolley to strike the raceway ends during its stroke and the trolley to properly work in the time.*
- 4- Tighten all the suspension screws while checking that all the line is locked.*
- 5- Verify that all the line is properly aligned.*
- 6- Insert the first head (without the saddle), fixing it at the end opposite to that where the line will be connected to the feeding line.*
- 7- Insert the trailer into the raceway at the headless end.*
- 8- Insert now all the trolleys that will have to carry the feeding cable, proceeding the same way as above.*
- 9- Position the remaining head (with the saddle) and fix it in such a way that the line is closed. The line closing prevents the trailer and the trolleys to come out.*
- 10- Insert the conductor cable into the trolley, between the saddle and the countersaddle. Start inserting the saddle from the head until reaching the trailer.*
- 11- Tighten the trolley screws fixing the cable between the saddle and the countersaddle, paying attention to as the cable into the trolley does not slide at all.*
- 12- Leave a quantity of cable between each trolley equal to the required loop.*

ISTRUZIONI DI MONTAGGIO - linea con pulsantiera -
ASSEMBLY INSTRUCTIONS - line with push-button panel -

Nel caso si debba montare la linea di azionamento comandi, il procedimento è simile al precedente, avendo però l'accortezza di inserire al posto del traino (precedente punto 7) il connettore. Il montaggio del connettore avviene nel modo seguente.

- 1- Preparare il cavo piatto montato sulla linea, eliminando 3 cm circa di guaina esterna e 1 cm circa di guaina per ogni singolo cavetto interno.
 - 2- Far passare il cavo piatto tra la sella e la piastra del connettore.
 - 3- Aprire il connettore: se si tratta di connettore in nylon (nei colori: arancio, azzurro o giallo), fare leva sull'estremità della molla mediante un utensile (pinza o cacciavite); se si tratta di connettore metallico, premere le due leve esterne in modo da liberare l'aggancio. Rimuovere quindi il coperchio.
 - 4- Prendere i frutti all'interno del connettore e separarli, nel caso non lo fossero già.
 - 5- Far passare il cavo piatto attraverso il pressacavo posto sulla base del connettore.
 - 6- Connettere il cavo piatto della linea al frutto femmina (frutto senza i pioli di contatto esterni), inserendo i singoli cavetti nelle apposite sedi numerate e serrando le viti relative a ogni sede per bloccare il cavo. La sequenza di connessione dei cavi è a cura dell'installatore a seconda delle proprie esigenze.
 - 7- Inserire il frutto femmina nella base del connettore bloccandolo mediante le quattro viti poste agli angoli.
 - 8- Serrare le viti del pressacavo sulla base del connettore onde evitare l'ingresso di polvere o altro.
 - 9- Serrare le viti della sella lasciando abbondante il cavo tra la sella e il pressacavo.
 - 10- Far passare il cavo tondo della pulsantiera attraverso il pressacavo del coperchio del connettore, dopo aver separato, per circa 40-50 cm, il cavo stesso dai cavetti metallici laterali.
 - 11- Eliminare le guaine come indicato per il cavo piatto e connettere il cavo tondo al frutto maschio (quello con i pioli di contatto esterni), avendo cura di seguire le istruzioni date per il frutto femmina e seguendo lo stesso ordine di connessione.
 - 12- Fissare il frutto maschio al coperchio del connettore utilizzando le quattro viti poste agli angoli dello stesso.
 - 13- Applicare il coperchio del connettore alla base, avendo cura di far coincidere i due frutti, quindi serrarlo utilizzando le leve, per i connettori di tipo STANDARD, o la molla, per connettore tipo CARPEL in nylon.
 - 14- Far compiere al cavo tondo un giro completo, quindi fissare un cavetto laterale a ciascun tirante della piastra.
 - 15- Per mezzo di una fascetta fissare i cavetti laterali metallici al cavo tondo nel punto in cui questi si incontrano, evitando così che durante l'utilizzo i cavetti laterali si separino ulteriormente dal cavo tondo.
 - 16- Fissare ad un cavetto laterale il cavo tondo per mezzo di una fascetta in un punto del giro a vuoto del cavo.
- Questa operazione, unita a lasciare un giro a vuoto di cavo, è necessaria per evitare che durante l'utilizzo il tiro sul cavo vada a ripercuotersi sui contatti all'interno del connettore, anziché distribuirsi sui cavetti metallici.
- 17- Serrare il pressacavo posto sul coperchio del connettore girando la vite del pressacavo stesso al fine di evitare l'ingresso di polvere o altro.

Should the drive controls line be installed, the process is similar to the previous one but the connector must be inserted instead of the trailer (see previous point 7). Install the connector as follows:

- 1- *Mount the flat cable on the line and remove approx. 3 cm of external sheath and approx. 1 cm of sheath for each inside wire.*
- 2- *Run the flat cable between the saddle and the connector plate.*
- 3- *Open the connector: should it be a nylon one (orange, light blue or yellow coloured) lever, by a pro per tool (pliers or screwdriver), the spring end. Should it be a metal connector, press the two external levers for releasing the coupling. Remove the cover.*
- 4- *Take the contact blocks inside the connector. Separate them, if necessary.*
- 5- *Run the flat cable through the cable gland placed on the connector base.*
- 6- *Connect the line flat cable to the female contact block (contact block without the external contact pins) by inserting the single wires into the proper numbered seats. Fix the cable by tightening the relevant screws to each seat. The cable connection sequence is provided by the installer according to his own requirements.*
- 7- *Insert the female contact block into the connector base and lock it by the four screws placed at the edges.*
- 8- *Tighten the cable gland screws to the connector base, thus preventing any dust or other foreign matters to enter.*
- 9- *Tighten the saddle screws paying attention to leave a big quantity of cable between the saddle and the cable gland.*
- 10- *After separating the round cable from the side metal wires for approx. 40-50 cm, run the round cable of the push-button panel through the cable gland of the connector cover.*
- 11- *Remove the sheaths as described for the flat cable and connect the round cable to the male contact block (the one provided with the external contact pins), paying attention to follow the instructions and proceeding in the same order as done for the female contact block.*
- 12- *Fix the male contact block to the connector cover using the four screws placed on the cover edges.*
- 13- *Apply the connector cover to the base matching the two contact blocks, then tighten it with the levers for STANDARD connectors, or with the spring for the CARPEL nylon connector.*
- 14- *Be sure the round cable completes an entire revolution, then fix a side wire to each tie rod plate.*
- 15- *Fix the metal side wires to the round cable at the point where they meet, using a proper fastening clamp, thus avoiding the side wires to be further separated from the round cable during the operation.*
- 16- *Fix the round cable to a side wire using a proper fastening clamp in a point where the cable is idle running. This operation, besides assuring a cable idle running, is required to prevent the cable traction affecting the contacts inside the connector during the operations, instead of distributing on the metal wires.*
- 17- *Tighten the cable gland placed on the connector cover by turning the cable gland screw, thus avoiding any dust or other foreign matters to enter.*

By CARPEL[®] 
srl

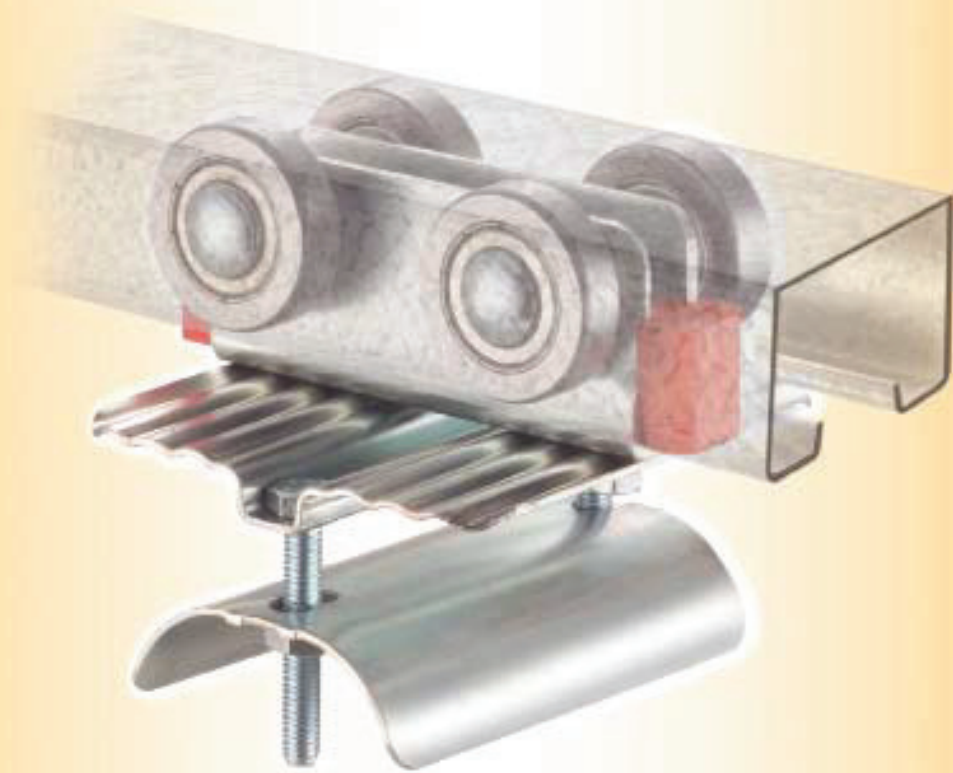

LINEA PORTACAVI “TIPO 2000” CABLE CARRYING LINE “TYPE 2000”

La linea portacavi tipo 2000 è un sistema pratico, efficiente e sicuro per la distribuzione dell'energia, sia essa elettrica, pneumatica o altro, per apparecchi mobili quali gru, carri ponti etc.

In questo catalogo troverete sicuramente la soluzione più adatta al vostro problema potendo scegliere tra più linee di carrelli portacavi tutti normalizzati per scorrere in maniera sicura, efficiente e duratura all'interno della canalina di nostra produzione.

Qualunque sia la scelta da voi operata, sarà una scelta di qualità e sicurezza in quanto su tutte le linee troverete apposto il marchio "CE" a garanzia che i nostri prodotti rispondono ai requisiti dettati dalla Direttiva Macchine 89/932 CEE e successivi emendamenti.

The cable carrying line type "2000" is a handy, efficient and safe system for electrical, pneumatic and other energy distribution to mobile equipment such as cranes, overhead traveling cranes, etc.

This catalogue includes various cable carrying lines; among them you will surely find the most suitable to your requirements. You may choose among several lines of cable carrying trolleys, all of them being standardized for assuring a safe, efficient and lasting sliding operation inside our cable raceway.

Regardless of your choice, it will assure you quality and safety; all our lines have been labelled with the "CE" mark, to guarantee that our products meet the 89/932/EEC Machinery Directive and further amendments.



Ci riserviamo la facoltà di apportare, senza alcun preavviso, modifiche costruttive al fine di migliorare le qualità tecniche, funzionali ed estetiche del prodotto.

We reserve the right to make modifications in order to improve the technical, functional and aesthetical qualities of our products without any prior notice.



AZIENDA CON SISTEMA QUALITÀ
CERTIFICATO DA DNV
=UNI EN ISO 9001/2000=

LINEA PORTACAVI "TIPO 2000" CABLE CARRYING LINE "TYPE 2000"



Canalina Portacavo Cable carrying raceway

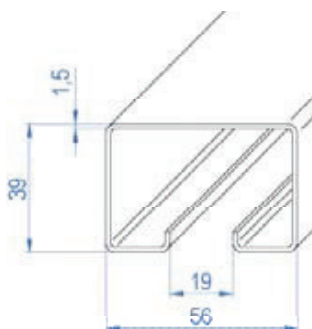
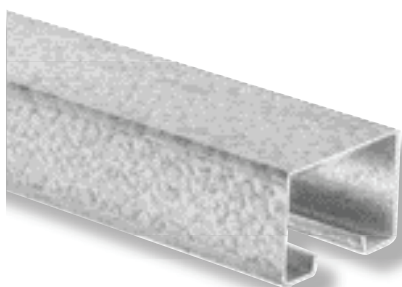

Materiale/Material	Acciaio zincato/Galvanized Steel
	Acciaio inox/Stainless steel
Spessore/Thickness	1,5 mm
Momento d'inerzia/Moment of inertia	6,7 cm ⁴
Momento resistente/Resisting moment	3,1 cm ³
Peso/Weight	2 kg/m
Distanza sospensioni/Suspension distance	2 m
Portata/Capacity	40 kg ogni/every 1,5 m

Articolo/Item	1
Codice barre/Bar code 3	CAN 2000 3
Codice barre/Bar code 3 m INOX	CAN 3M INOX
Codice barre/Bar code 4	CAN 2000 4
Codice barre/Bar code 5	CAN 2000 5
Codice barre/Bar code 6	CAN 2000 6

Testata semplice in nylon Nylon simple head

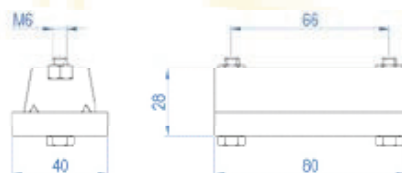

Materiale/Material	Corpo in nylon/Nylon body
	Acciaio zincato o inox/Galvanized steel or stainless steel
Peso/Weight	70 g

Articolo/Item	06
Codice/Code	TS 2 SEMPN
Codice/Code	TS 2 SEMPN I

Testata semplice in acciaio Steel simple head

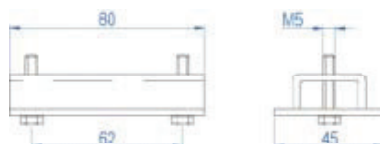
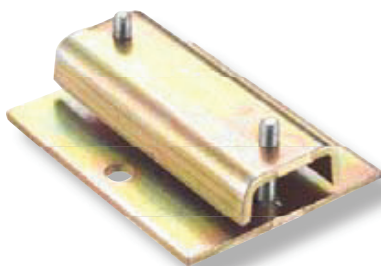

Materiale/Material	Acciaio zincato/Galvanized Steel
	Acciaio inox/Stainless steel
Peso/Weight	175 g

Articolo/Item	06
Codice/Code	TS 2 SEMPA
Codice/Code	TS 2 SEMPA I

LINEA PORTACAVI "TIPO 2000" CABLE CARRYING LINE "TYPE 2000"



Sospensione con fissaggio laterale Suspension with side fixing

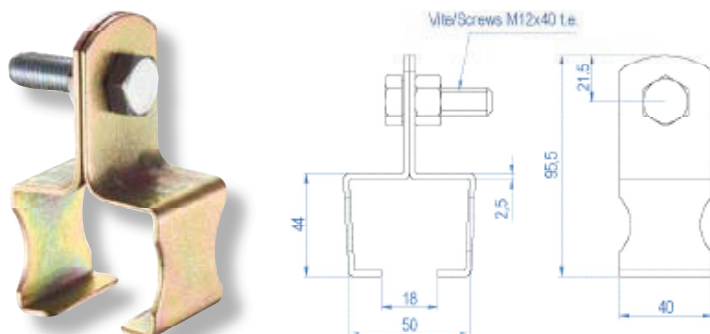

Materiale/Material	Acciaio zincato/Galvanized Steel	
	Acciaio inox/Stainless steel	
	con viti with screws	senza viti without screws
Peso/Weight	240 g	180 g
Portata/Capacity	35 kg	35 kg

Articolo/Item	04	05
Codice/Code	SOS 2 FLCV	SOS 2 FLSV
Codice/Code	SOS 2 FLCV I	SOS 2 FLSV I

Sospensione con fissaggio a parete Suspension with wall fixing

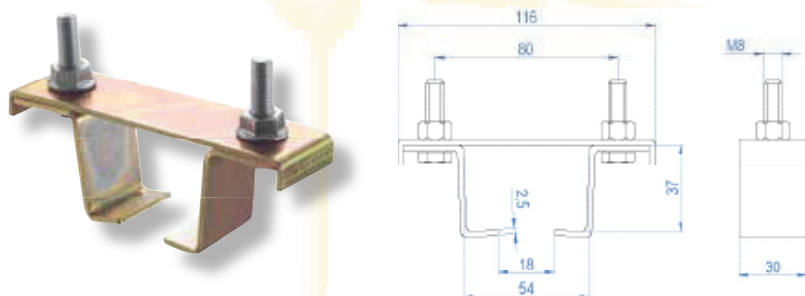

Materiale/Material	Acciaio zincato/Galvanized Steel	
	Acciaio inox/Stainless steel	
	con viti with screws	senza viti without screws
Peso/Weight	180 g	135 g
Portata/Capacity	50 kg	50 kg

Articolo/Item	05+05	05+05
Codice/Code	SOS 2 PACV	SOS 2 PASV
Codice/Code	SOS 2 PACV I	SOS 2 PASV I

Sospensione a parete con fissaggio di tipo composto Wall suspension with built-up fixing system

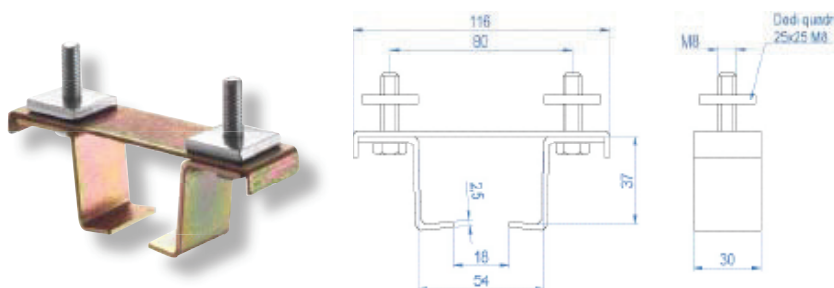

Materiale/Material	Acciaio zincato/Galvanized Steel	
Peso/Weight	195 g	
Portata/Capacity	50 kg	

Articolo/Item	05+05/C
Codice/Code	SOS 2 PATC

Giunto doppio in acciaio
Double steel joint

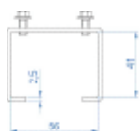
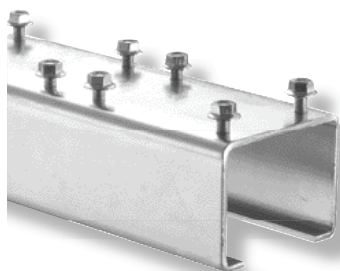

Materiale/ Material	Acciaio zincato/ Galvanized Steel
	Acciaio inox/ Stainless steel
Peso/ Weight	520 g

Articolo/ Item	03
Codice/ Code	GIU 2 FD
Codice/ Code	GIU 2 FD I

Giunto semplice in acciaio
Simple steel joint

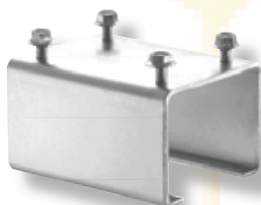

Materiale/ Material	Acciaio zincato/ Galvanized Steel
	Acciaio inox/ Stainless steel
Peso/ Weight	260 g

Articolo/ Item	02
Codice/ Code	GIU 2 FS
Codice/ Code	GIU 2 FS I

LINEA PORTACAVI "TIPO 2000"

CABLE CARRYING LINE "TYPE 2000"



Testata con sella

Head with saddle

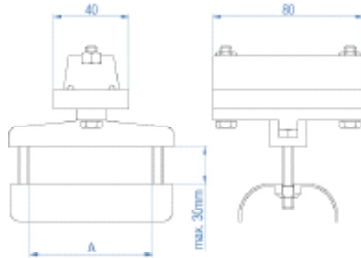

Materiale/Material	Corpo in nylon/Nylon body
Min. in acciaio zinc. o inox/Small parts in galvanized steel or stainless steel	
Portata/Capacity	30 kg

Sella/Saddle	Peso/Weight	Codice/Code	Articolo/Item
A= 35 mm	150 g	TSN2P35	301
A= 50 mm	165 g	TSN2P50	302
A= 65 mm	175 g	TSN2P65	303
A= 65 mm	175 g	TSN2P65I	303

Carrello portacavi

Cable carrying trolley

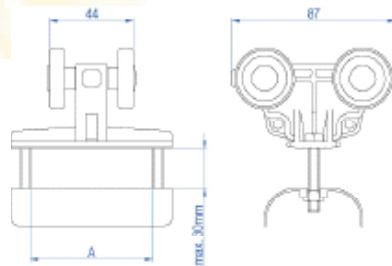

Materiale/Material	Corpo in nylon/Nylon body
Min. in acciaio zinc. o inox/Small parts in galvanized steel or stainless steel	

Ruote Nylon/Nylon Wheels	Ø 33 mm
Portata/Capacity	20 kg

Sella/Saddle	Peso/Weight	Codice/Code	Articolo/Item
A= 35 mm	140 g	CRN2P35N	321
A= 50 mm	150 g	CRN2P50N	322
A= 65 mm	160 g	CRN2P65N	323
A= 65 mm	160 g	CRN2P65NI	323

Cuscinetti rivestiti in nylon/Nylon coated bearing	Ø 32 mm
Portata/Capacity	25 kg

Sella/Saddle	Peso/Weight	Codice/Code	Articolo/Item
A= 35 mm	215 g	CRN2P35C	351
A= 50 mm	230 g	CRN2P50C	352
A= 65 mm	240 g	CRN2P65C	353
A= 65 mm	240 g	CRN2P65CI	353

Traino

Trailer

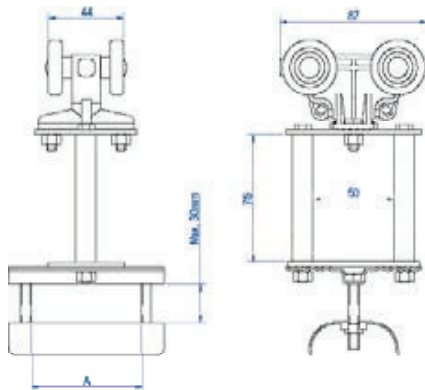
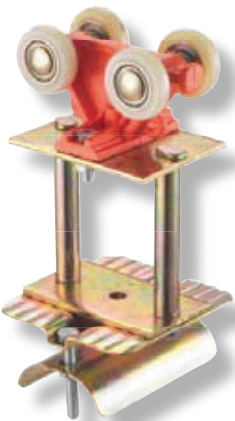

Materiale/Material	Corpo in nylon/Nylon body
Min. in acciaio zinc. o inox/Small parts in galvanized steel or stainless steel	

Ruote Nylon/Nylon Wheels	Ø 33 mm
Portata/Capacity	15 kg

Sella/Saddle	Peso/Weight	Codice/Code	Articolo/Item
A= 35 mm	160 g	TRN2P35N	331
A= 50 mm	170 g	TRN2P50N	332
A= 65 mm	180 g	TRN2P65N	333
A= 65 mm	180 g	TRN2P65NI	333

Cuscinetti rivestiti in nylon/Nylon coated bearing	Ø 32 mm
Portata/Capacity	20 kg

Sella/Saddle	Peso/Weight	Codice/Code	Articolo/Item
A= 35 mm	235 g	TRN2P35C	341
A= 50 mm	245 g	TRN2P50C	342
A= 65 mm	260 g	TRN2P65C	343
A= 65 mm	260 g	TRN2P65C I	343

LINEA PORTACAVI "TIPO 2000" CABLE CARRYING LINE "TYPE 2000"



Testata con sella Head with saddle

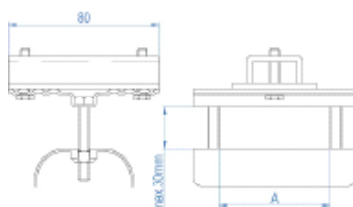

Materiale/Material	Corpo e Minuteria in acciaio zincato o inox
	Body and Small parts in galvanized steel or in stainless steel
Portata/Capacity	40 kg

Sella/Saddle	Peso/Weight	Codice/Code	Articolo/Item
A= 25 mm	255 g	TSA2P25	401
A= 35 mm	275 g	TSA2P35	402
A= 55 mm	300 g	TSA2P55	403
A= 65 mm	315 g	TSA2P65-TSA2P65 I	404
A= 80 mm	335 g	TSA2P80	405
A= 100 mm	365 g	TSA2P10	406

Carrello portacavi Cable carrying trolley

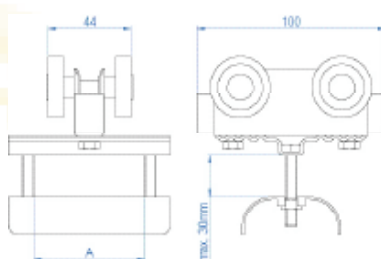

Materiale/Material	Corpo e Minuteria in acciaio zincato o inox
	Body and Small parts in galvanized steel or in stainless steel

Ruote Nylon/Nylon Wheels	Ø 33 mm
Portata/Capacity	30 kg

Sella/Saddle	Peso/Weight	Codice/Code	Articolo/Item
A= 25 mm	255 g	CRA2P25N	421
A= 35 mm	275 g	CRA2P35N	422
A= 55 mm	290 g	CRA2P55N	423
A= 65 mm	320 g	CRA2P65N-CRA2P65NI	424
A= 80 mm	335 g	CRA2P80N	425
A= 100 mm	360 g	CRA2P10N	426

Cuscinetti in acciaio/Steel bearing	Ø 32 mm
Portata/Capacity	35 kg

Sella/Saddle	Peso/Weight	Codice/Code	Articolo/Item
A= 25 mm	330 g	CRA2P25C	451
A= 35 mm	350 g	CRA2P35C	452
A= 55 mm	365 g	CRA2P55C	453
A= 65 mm	395 g	CRA2P65C-CRA2P65 CI	454
A= 80 mm	410 g	CRA2P80C	455
A= 100 mm	435 g	CRA2P10C	456

Traino Trailer

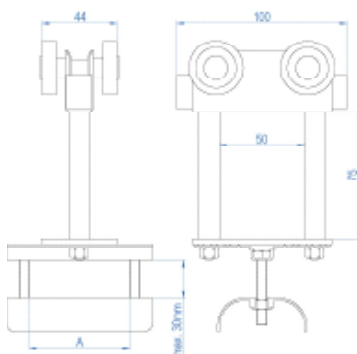

Materiale/Material	Corpo e Minuteria in acciaio zincato o inox
	Body and Small parts in galvanized steel or in stainless steel

Ruote Nylon/Nylon Wheels	Ø 33 mm
Portata/Capacity	25 kg

Sella/Saddle	Peso/Weight	Codice/Code	Articolo/Item
A= 25 mm	355 g	TRA2P25N	431
A= 35 mm	375 g	TRA2P35N	432
A= 55 mm	400 g	TRA2P55N	433
A= 65 mm	415 g	TRA2P65N-TRA2P65NI	434
A= 80 mm	435 g	TRA2P80N	435
A= 100 mm	460 g	TRA2P10N	436

Cuscinetti in acciaio/Steel bearing	Ø 32 mm
Portata/Capacity	30 kg

Sella/Saddle	Peso/Weight	Codice/Code	Articolo/Item
A= 25 mm	435 g	TRA2P25C	441
A= 35 mm	455 g	TRA2P35C	442
A= 55 mm	480 g	TRA2P55C	443
A= 65 mm	495 g	TRA2P65C -TRA2P65C I	444
A= 80 mm	515 g	TRA2P80C	445
A= 100 mm	540 g	TRA2P10C	446

Testata sella girevole
Head with slewing saddle

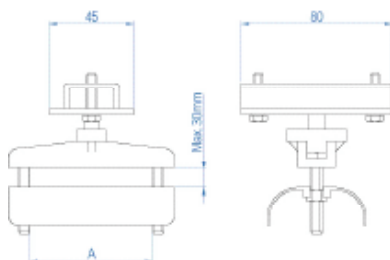
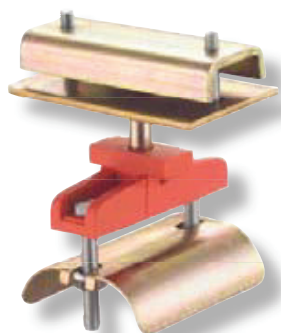

Materiale/Material	Acciaio zincato/Galvanized Steel
Portata/Capacity	30 kg

Sella/Saddle	Peso/Weight	Codice/Code	Articolo/Item
A= 35 mm	315 g	TSA2P35SG	402-G
A= 50 mm	340 g	TSA2P55SG	403-G
A= 65 mm	355 g	TSA2P65SG	404-G

Carrello sella girevole
Trolley with slewing saddle

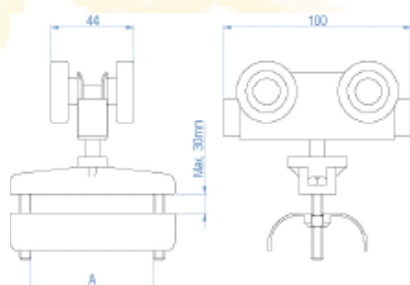
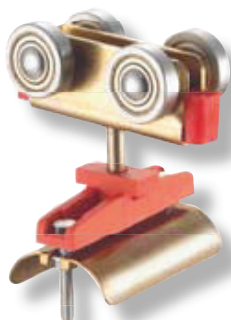

Materiale/Material	Acciaio zincato/Galvanized Steel
Ruote/Wheels	Cuscinetti acciaio/Steel bearings Ø 32 mm
Portata/Capacity	25 kg

Sella/Saddle	Peso/Weight	Codice/Code	Articolo/Item
A= 35 mm	390 g	CRA2P35SG	452-G
A= 50 mm	405 g	CRA2P55SG	453-G
A= 65 mm	435 g	CRA2P65SG	454-G

Traino sella girevole
Trailer with slewing saddle

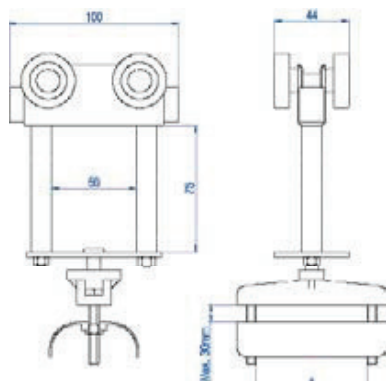
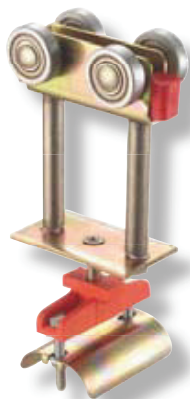

Materiale/Material	Acciaio zincato/Galvanized Steel
Ruote/Wheels	Cuscinetti acciaio/Steel bearings Ø 32 mm
Portata/Capacity	20 kg

Sella/Saddle	Peso/Weight	Codice/Code	Articolo/Item
A= 35 mm	490 g	TRA2P35SG	442-G
A= 50 mm	505 g	TRA2P55SG	443-G
A= 65 mm	535 g	TRA2P65SG	444-G

Testata con morsetto
Head with clamp

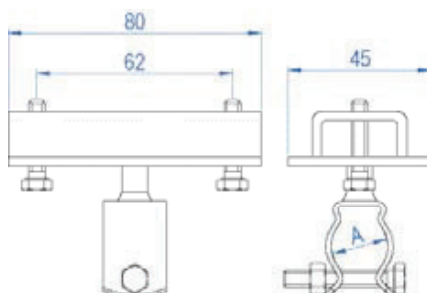
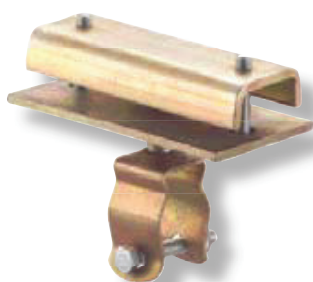

Materiale/Material	Acciaio zincato/Galvanized Steel
Portata/Capacity	30 kg
A (Ø max cavo/Cable max)	22 mm
Peso/Weight	205 g

Articolo/Item	602
Codice/Code	TSA 2 M22

Carrello con morsetto
Trolley with clamp

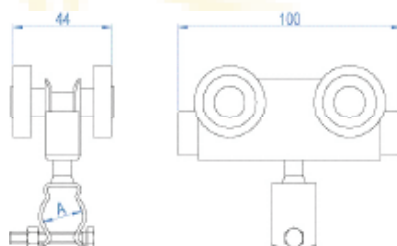
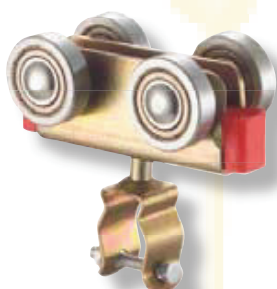

Materiale/Material	Acciaio zincato/Galvanized Steel
Ruote/Wheels	Nylon Ø 33 mm
	Cuscinetti acciaio/Steel bearings Ø 32 mm
A (Ø max cavo/Cable max)	22 mm

	Ruote nylon	Ruote cuscinetto
	Nylon wheels	Wheels with bearing
Peso/Weight	195 g	270 g
Portata/Capacity	20 kg	25 kg

Articolo/Item	603	604
Codice/Code	CRA 2 M22N	CRA 2 M22C

Traino con morsetto
Trailer with clamp

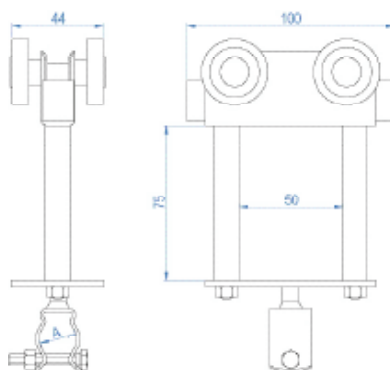
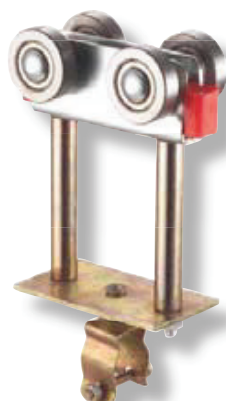

Materiale/Material	Acciaio zincato/Galvanized Steel
Ruote/Wheels	Nylon Ø 33 mm
	Cuscinetti acciaio/Steel bearings Ø 32 mm
A (Ø max cavo/Cable max)	22 mm

	Ruote nylon	Ruote cuscinetto
	Nylon wheels	Wheels with bearing
Peso/Weight	380 g	455 g
Portata/Capacity	15 kg	20 kg

Articolo/Item	631	632
Codice/Code	TRA 2 M22N	TRA 2 M22C

LINEA PORTACAVI "TIPO 2000"
CABLE CARRYING LINE "TYPE 2000"



Connettore per cavo piatto - presa tipo CARPEL
Connector for flat cable - socket type CARPEL

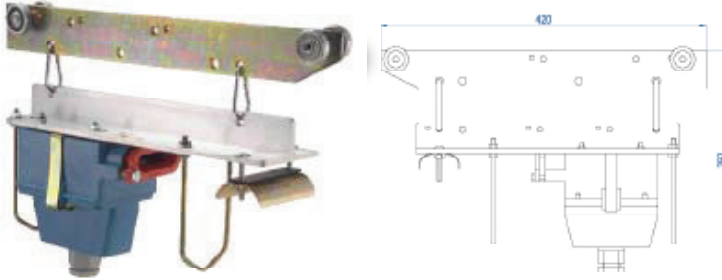

Materiale/Material	Piastra in alluminio/Aluminium plate
	Presa in nylon/Nylon socket
	Stecca in acciaio zincato/Galvanized steel slat
	Minuteria in acciaio zincato/Small parts in galvanized steel
Ruote/Wheels	Cuscinetti acciaio/Steel bearings Ø 32 mm
Portata/Capacity	40 kg
Peso/Weight	2900 g

Articolo/Item	1009	1010	1011
Codice/Code	CON 2 P10	CON 2 P16	CON 2 P24
	10 Poli/Pole	16 Poli/Pole	24 Poli/Pole

Connettore per cavo piatto - presa tipo STANDARD
Connector for flat cable - socket type STANDARD

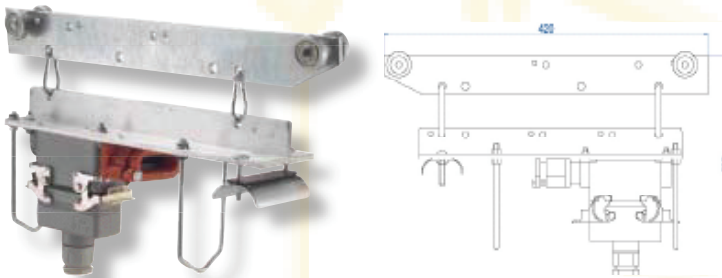

Materiale/Material	Piastra in alluminio/Aluminium plate
	Presa in alluminio/Aluminium socket
	Stecca in acciaio zincato/Galvanized steel slat
	Minuteria in acciaio zincato/Small parts in galvanized steel
Ruote/Wheels	Cuscinetti acciaio/Steel bearings Ø 32 mm
Portata/Capacity	40 kg
Peso/Weight	2660 g

Articolo/Item	1029	1030	1031	1032
Codice/Code	CON 2 P10I	CON 2 P16I	CON 2 P24I	CON 2 P32I
	10 Poli/Pole	16 Poli/Pole	24 Poli/Pole	32 Poli/Pole

Connettore per cavo tondo - presa tipo STANDARD
Connector for round cable - socket type STANDARD

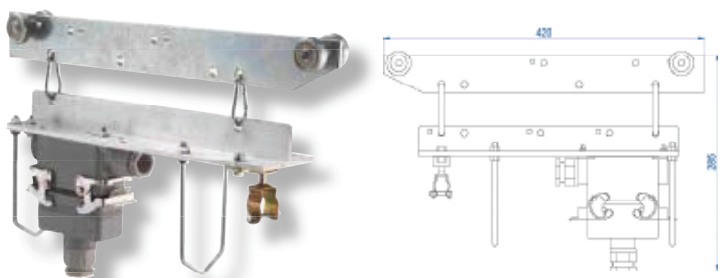

Materiale/Material	Piastra in alluminio/Aluminium plate
	Presa in alluminio/Aluminium socket
	Stecca in acciaio zincato/Galvanized steel slat
	Minuteria in acciaio zincato/Small parts in galvanized steel
Ruote/Wheels	Cuscinetti acciaio/Steel bearings Ø 32 mm
Portata/Capacity	40 kg
Peso/Weight	2885 g

Articolo/Item	1019	1020	1021	1022
Codice/Code	CON 2 T10	CON 2 T16	CON 2 T24	CON 2 T32
	10 Poli/Pole	16 Poli/Pole	24 Poli/Pole	32 Poli/Pole

LINEA PORTACAVI "TIPO 2000" CABLE CARRYING LINE "TYPE 2000"



Traino speciale Special trailer

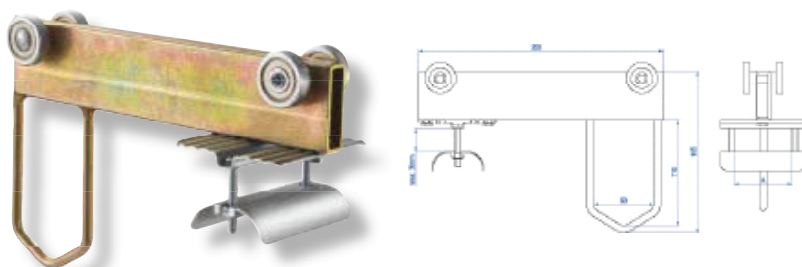

Materiale/Material *Acciaio zincato/Galvanized Steel*

Ruote Nylon/Nylon Wheels \varnothing 33 mm
Portata/Capacity 35 kg

Sella/Saddle	Peso/Weight	Codice/Code	Articolo/Item
A= 25 mm	695 g	TRP2P25N	RN25
A= 40 mm	735 g	TRP2P40N	RN40
A= 55 mm	765 g	TRP2P55N	RN55
A= 65 mm	785 g	TRP2P65N	RN65
A= 85 mm	855 g	TRP2P85N	RN85
A= 100 mm	890 g	TRP2P10N	RN10

Cuscinetti in acciaio/Steel bearing \varnothing 32 mm
Portata/Capacity 40 kg

Sella/Saddle	Peso/Weight	Codice/Code	Articolo/Item
A= 25 mm	765 g	TRP2P25C	RC25
A= 40 mm	805 g	TRP2P40C	RC40
A= 55 mm	835 g	TRP2P55C	RC55
A= 65 mm	855 g	TRP2P65C	RC65
A= 85 mm	925 g	TRP2P85C	RC85
A= 100 mm	960 g	TRP2P10C	RC10

Traino con sella centrale Trailer with central saddle

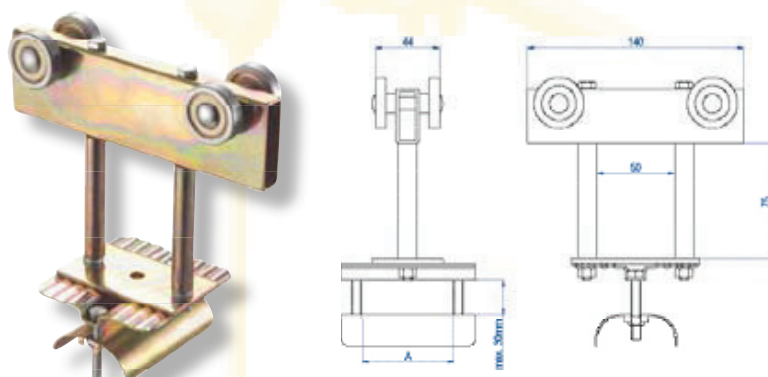

Materiale/Material *Acciaio zincato/Galvanized Steel*

Ruote/Wheels Cuscinetti acciaio/Steel bearings \varnothing 32 mm
Portata/Capacity 35 kg

Sella/Saddle	Peso/Weight	Codice/Code	Articolo/Item
A= 25 mm	545 g	TR2SCS25	225
A= 35 mm	585 g	TR2SCS35	235
A= 55 mm	615 g	TR2SCS55	255
A= 65 mm	635 g	TR2SCS65	265
A= 85 mm	705 g	TR2SCS85	280
A= 100 mm	740 g	TR2SCS10	210

Griffa portacavi Cable carrying claw

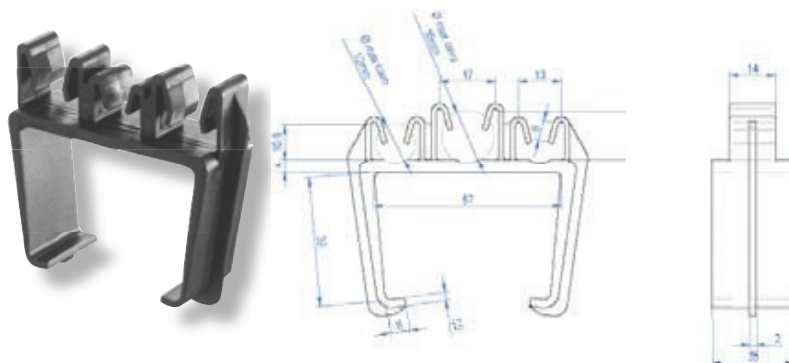

Materiale/Material Nylon
Peso/Weight 20 g

Articolo/Item 4202
Codice/Code GRIFFA/2000



ISTRUZIONI DI MONTAGGIO - linea con traino -
ASSEMBLY INSTRUCTIONS - line with trailer -

- 1- Posizionare le sospensioni nelle proprie sedi (pareti o mensole); in questa fase di montaggio non bisogna stringere eccessivamente le viti delle sospensioni, in modo da permettere l'inserimento delle barre di canalina ed il loro eventuale posizionamento.
- 2- Inserire le barre di canalina nelle sospensioni; verificare la presenza di un numero adeguato di sospensioni su tutta la linea.
In questa fase è necessario prestare particolare attenzione allo "spigolo vivo" del taglio della canalina: tale spigolo è necessario per un corretto allineamento delle parti di canalina da unire e per far scorrere correttamente il carrello all'interno.
- 3- Applicare i giunti alle estremità delle barre, quindi serrare le viti senza deformare la canalina. Le estremità delle canaline devono essere adiacenti e ben allineate (la conformazione del giunto impedisce il non allineamento delle canaline) onde evitare che il carrello durante la corsa urti contro l'estremità della canalina e che, con il passare del tempo, sia pregiudicato il buon funzionamento del carrello stesso.
- 4- Serrare tutte le viti delle sospensioni verificando nel medesimo tempo il bloccaggio dell'intera linea.
- 5- Verificare l'allineamento dell'intera linea.
- 6- Inserire la prima testata (senza sella) e fissarla all'estremità opposta a quella in cui la linea si allaccerà all'alimentazione.
- 7- Inserire il traino nella canalina nell'estremità senza testata.
- 8- Di seguito, nello stesso modo, inserire tutti i carrelli che sosterranno il cavo di alimentazione
- 9- Posizionare la testata rimanente (con sella) e fissarla in modo da chiudere la linea. La chiusura della linea impedisce la fuoriuscita del traino e dei carrelli.
- 10- Inserire il cavo conduttore nel carrello, tra sella e controsella, partendo dalla testata con la sella sino ad arrivare al traino.
- 11- Stringere le viti del carrello, fissando il cavo tra sella e controsella, avendo cura di verificare che non sia presente movimento di scorrimento del cavo nel carrello.
- 12- Lasciare tra carrello e carrello una quantità di cavo pari all'ansa desiderata.

- 1- Place the suspensions into their seats (walls or brackets), without overtightening the suspension screws so as to allow the raceway bars to be inserted and positioned, if necessary.
- 2- Insert the raceway bars into the suspensions; be sure that a proper number of suspensions are all over the line.
In this phase particular attention has to be paid to the "sharp edge" of the raceway cutting side: such an edge is required to properly align the raceway parts to be connected and for the trolley to properly slide inside.
- 3- Apply the joints to the bar ends, then tighten the screws without deforming the raceway. The raceway ends must be adjacent and well aligned (the joint configuration avoids the raceway misalignment) preventing the trolley to strike the raceway ends during its stroke and the trolley to properly work in the time.
- 4- Tighten all the suspension screws while checking that all the line is locked.
- 5- Verify that all the line is properly aligned.
- 6- Insert the first head (without the saddle), fixing it at the end opposite to that where the line will be connected to the feeding line.
- 7- Insert the trailer into the raceway at the headless end.
- 8- Insert now all the trolleys that will have to carry the feeding cable, proceeding the same way as above.
- 9- Position the remaining head (with the saddle) and fix it in such a way that the line is closed. The line closing prevents the trailer and the trolleys to come out.
- 10- Insert the conductor cable into the trolley, between the saddle and the countersaddle. Start inserting the saddle from the head until reaching the trailer.
- 11- Tighten the trolley screws fixing the cable between the saddle and the countersaddle, paying attention so as the cable into the trolley does not slide at all.
- 12- Leave a quantity of cable between each trolley equal to the required loop.

ISTRUZIONI DI MONTAGGIO - linea con pulsantiera -
ASSEMBLY INSTRUCTIONS - line with push-button panel -

Nel caso si debba montare la linea di azionamento comandi il procedimento è simile al precedente, avendo però l'accortezza di inserire al posto del traino (precedente punto 7) il connettore. Il montaggio del connettore avviene nel modo seguente:

- 1- Preparare il cavo piatto montato sulla linea, eliminando 3 cm circa di guaina esterna e 1 cm circa di guaina per ogni singolo cavetto interno.
 - 2- Far passare il cavo piatto tra la sella e la piastra del connettore.
 - 3- Aprire il connettore: se si tratta di connettore in nylon (nei colori: arancio, azzurro o giallo), fare leva sull'estremità della molla mediante un utensile (pinza o cacciavite); se si tratta di connettore metallico, premere le due leve esterne in modo da liberare l'aggancio. Rimuovere quindi il coperchio.
 - 4- Prendere i frutti all'interno del connettore e separarli, nel caso non lo fossero già.
 - 5- Far passare il cavo piatto attraverso il pressacavo posto sulla base del connettore.
 - 6- Connettere il cavo piatto della linea al frutto femmina (frutto senza i pioli di contatto esterni), inserendo i singoli cavetti nelle apposite sedi numerate e serrando le viti relative a ogni sede per bloccare il cavo. La sequenza di connessione dei cavi è a cura dell'installatore a seconda delle proprie esigenze.
 - 7- Inserire il frutto femmina nella base del connettore bloccandolo mediante le quattro viti poste agli angoli.
 - 8- Serrare le viti del pressacavo sulla base del connettore onde evitare l'ingresso di polvere o altro.
 - 9- Serrare le viti della sella lasciando abbondante il cavo tra la sella e il pressacavo.
 - 10- Far passare il cavo tondo della pulsantiera attraverso il pressacavo del coperchio del connettore, dopo aver separato, per circa 40-50 cm, il cavo stesso dai cavetti metallici laterali.
 - 11- Eliminare le guaine come indicato per il cavo piatto e connettere il cavo tondo al frutto maschio (quello con i pioli di contatto esterni), avendo cura di seguire le istruzioni date per il frutto femmina e seguendo lo stesso ordine di connessione.
 - 12- Fissare il frutto maschio al coperchio del connettore utilizzando le quattro viti poste agli angoli dello stesso.
 - 13- Applicare il coperchio del connettore alla base, avendo cura di far coincidere i due frutti, quindi serrarlo utilizzando le leve, per i connettori di tipo STANDARD, o la molla, per connettore tipo CARPEL in nylon.
 - 14- Far compiere al cavo tondo un giro completo, quindi fissare un cavetto laterale a ciascun tirante della piastra.
 - 15- Per mezzo di una fascetta fissare i cavetti laterali metallici al cavo tondo nel punto in cui questi si incontrano, evitando così che durante l'utilizzo i cavetti laterali si separino ulteriormente dal cavo tondo.
 - 16- Fissare ad un cavetto laterale il cavo tondo per mezzo di una fascetta in un punto del giro a vuoto del cavo.
- Questa operazione, unita a lasciare un giro a vuoto di cavo, è necessaria per evitare che durante l'utilizzo il tiro sul cavo vada a ripercuotersi sui contatti all'interno del connettore, anziché distribuirsi sui cavetti metallici.
- 17- Serrare il pressacavo posto sul coperchio del connettore girando la vite del pressacavo stesso al fine di evitare l'ingresso di polvere o altro.

Should the drive controls line be installed, the process is similar to the previous one but the connector must be inserted instead of the trailer (see previous point 7). Install the connector as follows:

- 1- *Mount the flat cable on the line and remove approx. 3 cm of external sheath and approx. 1 cm of sheath for each inside wire.*
 - 2- *Run the flat cable between the saddle and the connector plate.*
 - 3- *Open the connector: should it be a nylon one (orange, light blue or yellow coloured) lever, by a proper tool (pliers or screwdriver), the spring end. Should it be a metal connector (grey coloured), press the two external levers for releasing the coupling. Remove the cover.*
 - 4- *Take the contact blocks inside the connector. Separate them, if necessary.*
 - 5- *Run the flat cable through the cable gland placed on the connector base.*
 - 6- *Connect the line flat cable to the female contact block (contact block without the external contact pins) by inserting the single wires into the proper numbered seats. Fix the cable by tightening the relevant screws to each seat. The cable connection sequence is provided by the installer according to his own requirements.*
 - 7- *Insert the female contact block into the connector base and lock it by the four screws placed at the edges.*
 - 8- *Tighten the cable gland screws to the connector base, thus preventing any dust or other foreign matters to enter.*
 - 9- *Tighten the saddle screws paying attention to leave a big quantity of cable between the saddle and the cable gland.*
 - 10- *After separating the round cable from the side metal wires for approx. 40-50 cm, run the round cable of the push-button panel through the cable gland of the connector cover.*
 - 11- *Remove the sheaths as described for the flat cable and connect the round cable to the male contact block (the one provided with the external contact pins), paying attention to follow the instructions and proceeding in the same order as done for the female contact block.*
 - 12- *Fix the male contact block to the connector cover using the four screws placed on the cover edges.*
 - 13- *Apply the connector cover to the base matching the two contact blocks, then tighten it with the levers for STANDARD connectors, or with the spring for the CARPEL nylon connector.*
 - 14- *Se sure the round cable completes an entire revolution, then fix a side wire to each tie rod plate.*
 - 15- *Fix the metal side wires to the round cable at the point where they meet, using a proper fastening clamp, thus avoiding the side wires to be further separated from the round cable during the operation.*
 - 16- *Fix the round cable to a side wire using a proper fastening clamp in a point where the cable is idle running.*
- This operation, besides assuring a cable idle running, is required to prevent the cable traction affecting the contacts inside the connector during the operations, instead of distributing on the metal wires.*
- 17- *Tighten the cable gland placed on the connector cover by turning the cable gland screw, thus avoiding any dust or other foreign matters to enter.*