

The image shows a close-up of an ATOLLO insulated conductor rail assembly. It consists of a long, orange, rectangular plastic housing that is partially cut away to reveal the internal components. Inside, there are several black, cylindrical contact fingers or rollers. Below the housing is a black metal bracket with a U-shaped bottom, which is mounted on a white spring. The entire assembly is set against a background of light blue and white geometric shapes.

ATOLLO

**INSULATED CONDUCTOR RAIL
FOR ELECTRICAL FEEDING OF CRANES**

Features, advantages and benefit

The insulated contact line ATOLLO® represents the best solution for the electrical feeding of cranes, hoists, bridge cranes, monorails, elevators, automated warehouses and several other mobile machines. It is patented, and in conformance with CE standard and certificated by LOVAG.

The insulated contact line ATOLLO® differs from other feeding systems for its several advantages:

- **High safety:** it is in conformance with the most severe international standards for safety requested to the latest-state-of-the-art electrical feeding system: impact protection against accidental contacts is guaranteed. Moreover the earth conductor has been marked with the relevant symbol, printed on the PVC housing;
- **High solidity:** the insulating housing and all components are compact, strong and corrosion-resistant;
- **Versatility:** it is suitable for straight rails as well as curves. Ideal for all applications either indoor or outdoor;
- **Quick and easy installation:** thanks to the design and development of all components (joint box, sectioning and inspection points, support release hangers etc) a quick and easy installation can be assured, even in critical conditions;
- **Maintenance free:** thanks to the careful study of all components, the maintenance of the line is extremely reduced;
- **Minimal encumbrance:** the space necessary for the installation is particularly reduced;
- **Foreseen conductors:** up to 5.



ISO9001

CE MARK: it guarantees that Cariboni's products are complying with the European standards concerning safety of products.



ISO14001

PATENT: the originality and the innovation of the insulated housing are covered by a Patent.



BS OHSAS 18001

Certificate **LOVAG - ACAE:** LOVAG is an organisation acknowledged by the European Organisation for all Tests and Certifications (EOTC) of the European Community.

ACAE is an Italian member of LOVAG.



The insulated contact line Atollo® is available in the following versions

CONTINUOUS CONDUCTORS: the housing and the relevant conductors are supplied separately.

PRE-MOUNTED CONDUCTORS: conductors have already been inserted in the housing before the shipment.

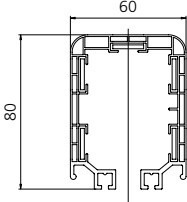
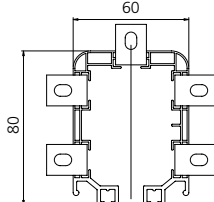
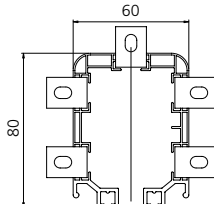
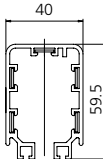
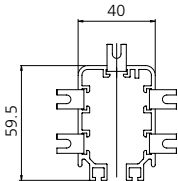
Amperage (A)	Continuous conductors (Line Type C)	Pre-mounted conductors (Line Type P)
ATOLLO® 70-100-140 Ampere	 see page 5	 see page 5
ATOLLO® 200 Ampere	---	 see page 5
MINI ATOLLO® 40-60 Ampere	 see page 19	 see page 19

Technical specifications

Operating voltage/frequency	600 V 50-60 Hz
Insulating voltage IEC 60439/2	3750 V
Trolley travel speed	maximum admissible 250 m/1' Tested 180 m/1'
Admissible environmental temperature at rated load (High temperatures version, PVC housing in white color)	-30°C +40°C -30°C +65°C
Maximum admissible temperature for the housing	+60°C
Storing temperature for the housing	-30°C +60°C
Short time withstand current:	
Line MINI ATOLLO® 40 ÷ 60 A	complete with 25 A trolley 500A x 1s
Line ATOLLO® 70 ÷ 200 A	complete with 35 A trolley 800A x 1s
Line ATOLLO® 70 ÷ 200 A	complete with 70 A trolley 2000A x 1s
PROTECTION DEGREE IP:	
without closing strip (for installation of the line out of possible hand contact) tested according to CEI EN 60529 standard	IP 13
completed with closing strip (for installation of the line in zone with possible hand contact) tested according to CEI EN 60529 standard	IP 23
Self extinguishing CEI EN 60695-1 standard: insulated housing and trolley	850 °C
other accessories	650 °C
Distance between supports:	MINI ATOLLO® 40 ÷ 60 A 1,33 m MAX ATOLLO® 70 ÷ 200 A 2 m MAX

Amperage (A)	Conductor section mm ²	Resistance a 20°C Ω/m 10 ⁻⁴	Impedance a 50 Hz Ω/m 10 ⁻⁴
40	10	17.80	17.87
60	15	11.87	11.96
70	16	11.16	11.25
100	24	7.44	7.57
140	32	5.58	5.72
200	48	3.72	4

Calculation for voltage drop:

In case of very long lines, it is necessary to verify the voltage drop. If the value is particularly high, more feeding points must be foreseen or as alternative, it's better to use a line with a higher voltage than the one previously foreseen.

For the calculation some data, such as motor power/type, coefficient of utilisation and current (inverter, squirrel cage, slip ring motor etc.) are necessary. As soon as these data are known, the following formula helps verifying the voltage drop rate:

$$\Delta V_{\%} = \frac{\sqrt{3} \cdot I \cdot l \cdot (R \cdot \cos \varphi + X \cdot \sin \varphi)}{V} \cdot 100$$

Where

- I: running current at the beginning
- l: line length (in case of end feeding point, it is equal to the total line length; on the other hand in case of intermediate feeding, this value is equal to the half total length of the line)
- R: line resistance
- X: line reactance
- Cosφ: hypothetical value of the power coefficient (average 0.7-0.8)
- V: voltage

ATOLLO[®] 70-100-140-200 A

Components

Line type C: continuous conductors - Line type P: pre-mounted conductors

LINE TYPE C: CONTINUOUS CONDUCTORS

FEATURES:

The contact conductors, cut according to the requested length, are inserted inside the housing as soon as it has been installed. In this way an electrical line with continuous conductors has been realised with a considerable reduction of mounting time. This version guarantees also a minimum voltage drop as well as reduced wear and tear on the contact shoes.

Inside the housing, a nib has been foreseen in order to avoid a wrong insertion of the trolley.



LINE TYPE C: INSULATED HOUSING WITH CONTINUOUS CONDUCTORS				
L (m)	Conductors N°	Code		
		70 A	100 A	140 A
4	4	03.03244.91	03.03244.92	03.03244.93
	5	03.03245.91	03.03245.92	03.03245.93
2	4	03.03224.91	03.03224.92	03.03224.93
	5	03.03225.91	03.03225.92	03.03225.93

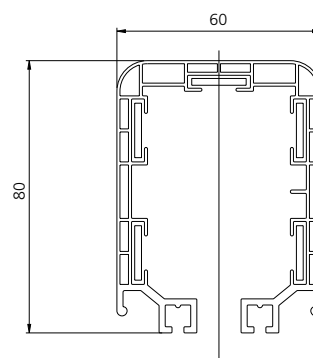

Note: available also au high temperatures version, suitable up to 65°C ambient. PVC housing in white color.

LINE TYPE P: PRE-MOUNTED CONDUCTORS

FEATURES:

The conductors are already inserted in the housing, inside the relevant seats. In order to facilitate the insertion, the extremities of the conductors have been bent and are ready for the joint with the relevant clamps.

Inside the housing, a nib has been foreseen in order to avoid the wrong insertion of the trolley.



LINE TYPE P: INSULATED HOUSING WITH PRE-MOUNTED CONDUCTORS					
L (m)	Conductors N°	Code			
		70 A	100 A	140 A	200 A
4	4	03.03004.91	03.03004.92	03.03004.93	03.03004.94
	5	03.03005.91	03.03005.92	03.03005.93	03.03005.94
2	4	03.03044.91	03.03044.92	03.03044.93	03.03044.94
	5	03.03045.91	03.03045.92	03.03045.93	03.03045.94

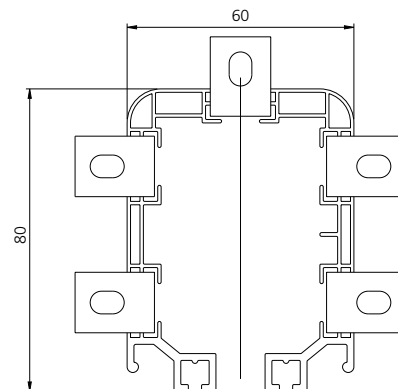

CURVES

It is also possible to supply lines with curves (minimum radius 1250mm 4 conductors). Thanks to the innovative system, the installation of curves is extremely easy and quick and can be applied to both versions of the lines (type C and type P).

Line type C: continuous conductors - Line type P: pre-mounted conductors

All plastic components are made by insulating and self-extinguishing material.

1 Joint box for housing

FEATURES:

Line Type C

CODE: **03.08014.91NS**

It serves to connect two sections of the insulated housing. The release application is very easy and can be carried out without screws and it's equipped with 4 nibs, which guarantee a safe fixing on the housing.

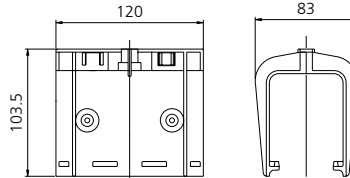

2 Joint box for housing

FEATURES:

Line Type C

CODE: **03.08012.90NN**

It serves to connect two sections of the insulated housing with joined conductors. Used in cases of extension of existing lines or with very long lines, where the conductor cannot be inserted in a single operation. Fixing on the junction made with 2 screws and nuts M6.

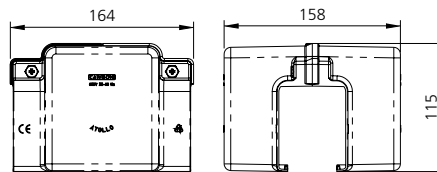

(to be used in case of the junctions are provided conductors)

3 Joint clamp

FEATURES:

Line Type C

CODE: **03.08013.90N**

It serves for the junction of conductors in case of extension of existing lines or of lines particularly long, where the conductors cannot be inserted in a single operation.

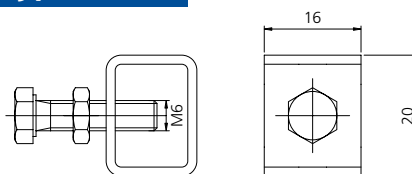

4 Joint box for fixed point

FEATURES:

Line Type C

CODE: **03.08014.93NS**

Applied on the joint point of two sections of housing and fixed to a support bracket in order to ensure the correct distribution of the expansion of the line.

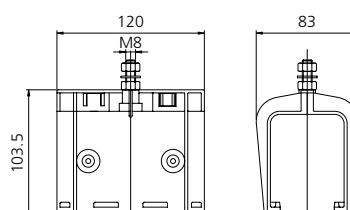

5 Joint box for housing

FEATURES:

Line Type P

CODE: **03.08012.90NM**

It serves to connect two sections of the housing in case of lines type P (pre-mounted conductors). Fixing on the junction made with 2 screws and nuts M6.

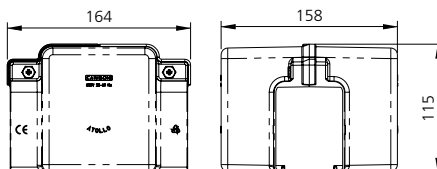

6 Joint clamp

FEATURES:

Line Type P

CODE: **03.08013.90LM**

It is necessary in case of junction of the contact conductors for the lines type P (Pre-mounted conductors). It is mounted on the copper already prepared for the assembling.

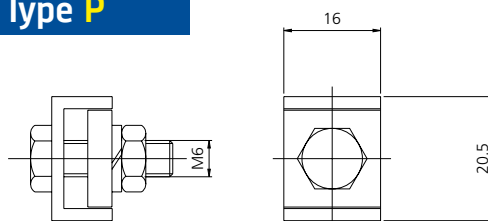

7 End feeder box

FEATURES:

Line Type C

CODE: **03.08016.90**

It is mounted at the end of the line. The removal of the back cover allows an easier installation.

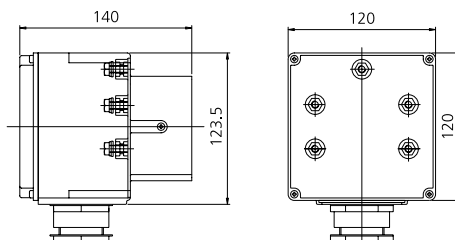

8 Line feeder box

FEATURES:

Line Type C/P

CODE: **03.08017.91N - 92N - 93N**

It can be mounted on each point of the line nearby the junction of 2 housing sections.

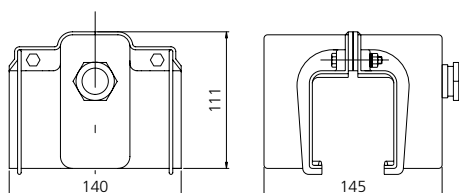

CODE	AMPERAGE (A)
03.08017.91N	70
03.08017.92N	100
03.08017.93N	140

Line type C: continuous conductors - Line type P: pre-mounted conductors

9 Terminal connector for feeder cable**FEATURES:** Line Type **C/P**CODE: **01.02773.90**

Inserted in the joint clamp, it serves to connect the cable (max. section 10 mm²) to the conductor, inside the line feeder box.

**10** Line feeder box for line with load 200A**FEATURES:** Line Type **P**CODE: **03.08017.99**

It can be mounted on each point of the line nearby the junction of 2 housing sections.

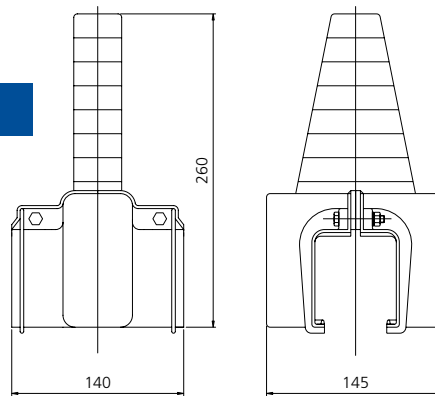
**11** Feeder clamps for line with load 200A**FEATURES:** Line Type **P**CODE: **03.08039.90**

It serves to connect the cable (max. section 50 mm²) to the conductor, inside the line feeder box 03.08017.99.

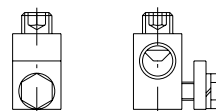
**12** Support hanger**FEATURES:** Line Type **C/P**CODE: **03.08018.91N**

Necessary to support the insulating housing and fixed to the support brackets, it permits the creep of the insulating housing due to expansion. The installation distance between 2 contiguous hangers must be max. 2 m.

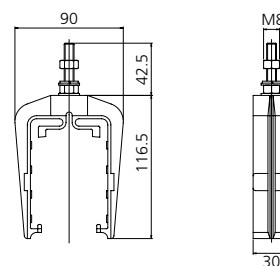

13 Fixed point hanger

FEATURES: Line Type **C/P**

CODE: **03.08019.90N**

Locked to the housing through 2 lateral screws it serves to obtain a fixed point in order to ensure an even distribution of the expansion.

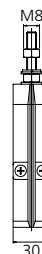
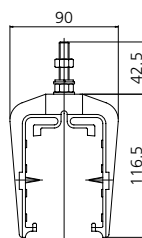

14 End closure box

FEATURES: Line Type **C/P**

CODE: **03.08023.90**

Fixed to the insulating housing, it serves to close the end of the line.

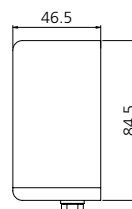
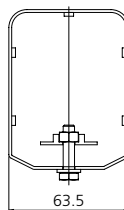

15 Simple strip for closure

FEATURES: Line Type **C/P**

CODE: **03.08007.90N**

Two flexible sealing strips, passed through the side grooves of the housing, ensure an additional protection of the insulating housing of the contact line from IP 13 to IP 23.

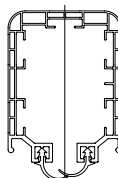

16 Expansion joint

FEATURES: Line Type **C**

CODICE: **03.03029.90**

Used in case of lines particularly long to compensate the insulating housing expansion. Installed between 2 fixed points, it is necessary to foresee a further support bracket.

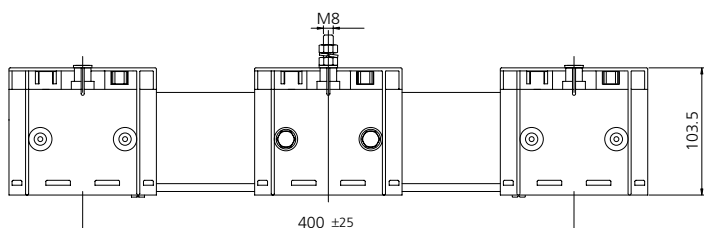

Line type C: continuous conductors - Line type P: pre-mounted conductors

17 Expansion joint

CODE: **03.54415.00**

Used in particularly long lines to compensate the expansion of the insulating housing. Installed between 2 fixed points. It is necessary to foresee a further support bracket.

FEATURES: Line Type **P**

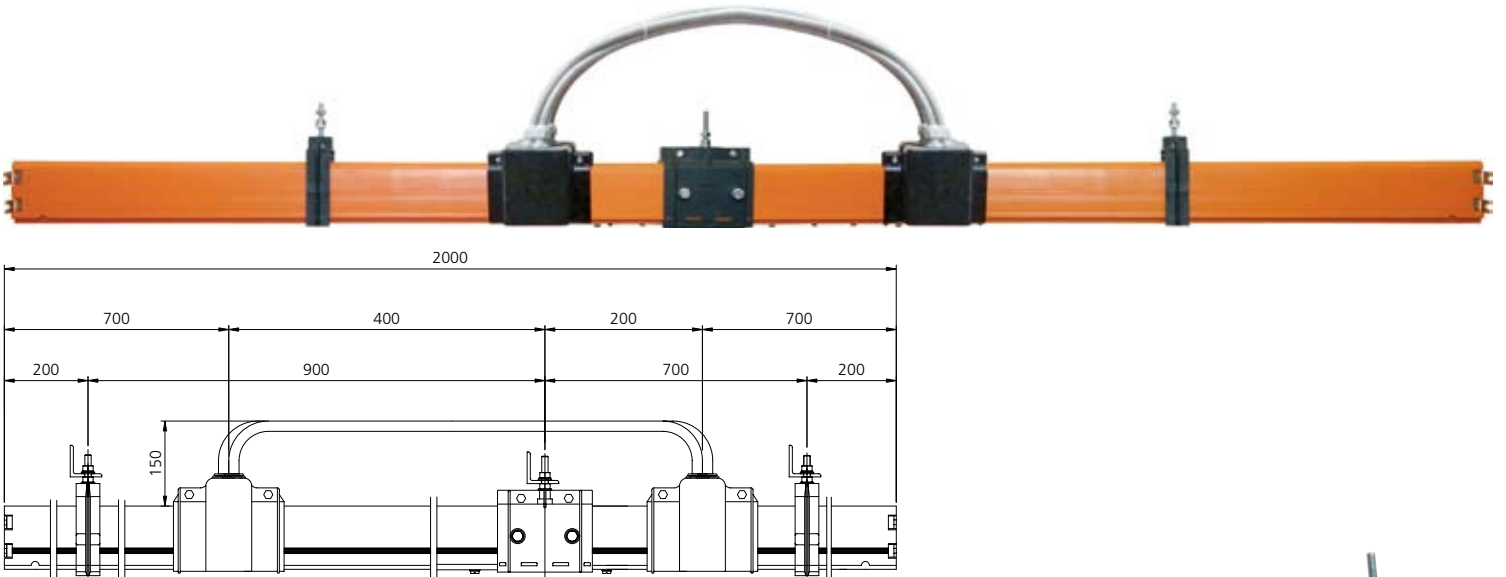

18 Inspection point

FEATURES: Line Type **C**

CODE: **03.03022.90**

It consists in a removable section of insulating housing, that allows the inspection and the eventual extraction of the collector trolley. For the installation, it's necessary to foresee 2 further support brackets.

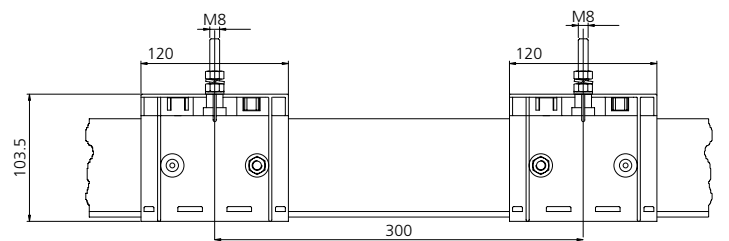

19 Sectionalizing joint

FEATURES: Line Type **C/P**

CODE: **03.03021.90**

It allows to divide electrically the line in various insulated sections, in order to create insulated maintenance areas.

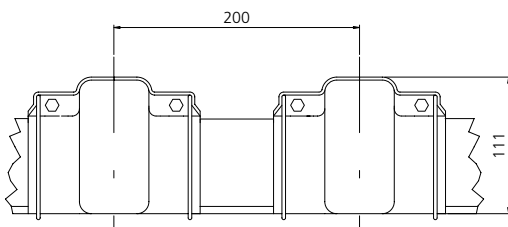

20 Transfer guide for collector trolley

FEATURES:

Line Type **C/P**

CODE: **03.08031.90NH5P**

It serves to facilitate the insertion of the current collector in case of interrupted line.

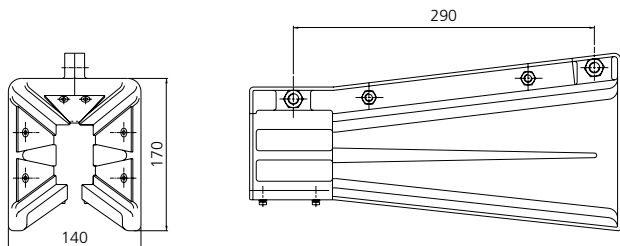

21 Alignment plates

FEATURES:

Line Type **C/P**

CODE: **5.090301.06**

Inserted in the side grooves of the housing, they ensure a perfect alignment nearby the junctions and an optimization of the current collector sliding.

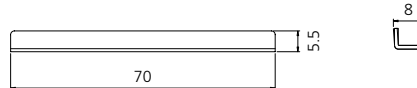

CURRENT COLLECTOR TROLLEYS

22 Current collector trolley with contact shoes 35 A

FEATURES:

Line Type **C**

The body is completely insulated and the contact shoes are made of metal carbon. Equipped with 5 m. cable and towing arm attachment (the towing arm code 03.08026.91 is not included).

Inside there is a terminal box, that can be easily reached for any eventual maintenance, without removing the current collector from the insulating housing.

In case of Amperage more than 35 A, a parallel connection with 2 or more collectors is necessary or, as alternative, a current collector trolley for higher amperages can be used as per the following table:

CODE	AMPERAGE (A)	CONTACT SHOES N°
03.08024.92NC	35 A	4
03.08024.93NC		5

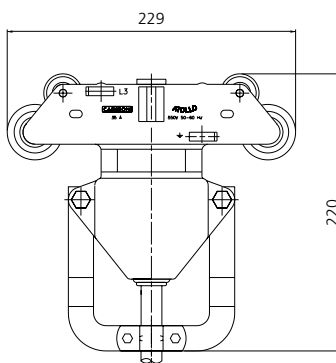

Line type C: continuous conductors - Line type P: pre-mounted conductors

23 Current collector trolley with contact shoes 35 A**FEATURES:****Line Type P**

Contact shoes are made of metal carbon; equipped with 5 m. cable, towing arm attachment (cod. 03.04019.90) and towing arm (cod. 03.08026.90) not included.

CODE	AMPERAGE (A)	CONTACT SHOES N°
03.08024.92C5	35 A	4
03.08024.93C5		5

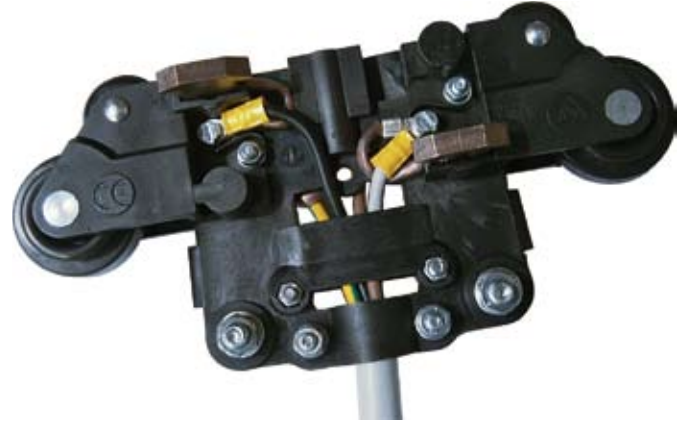
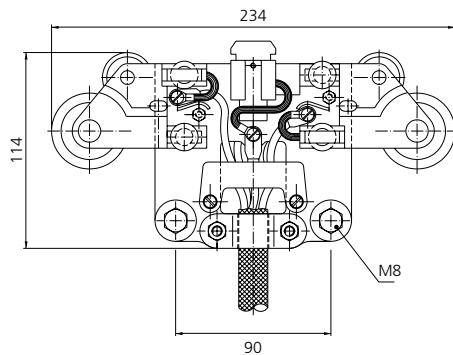
**24** Current collector trolley with contact shoes 70 A**FEATURES:****Line Type C/P**

The body is completely insulated and the contact shoes are made of metal carbon. Equipped with 5 m. cable (the towing arm code 03.08026.91 and towing arm attachment code 03.08025.91 are not included). In case of higher Amperage than 70 A, 2 or more current collectors must be connected together.

CODE	AMPERAGE (A)	CONTACT SHOES N°
03.08034.92C5	70 A	4
03.08034.93C5		5

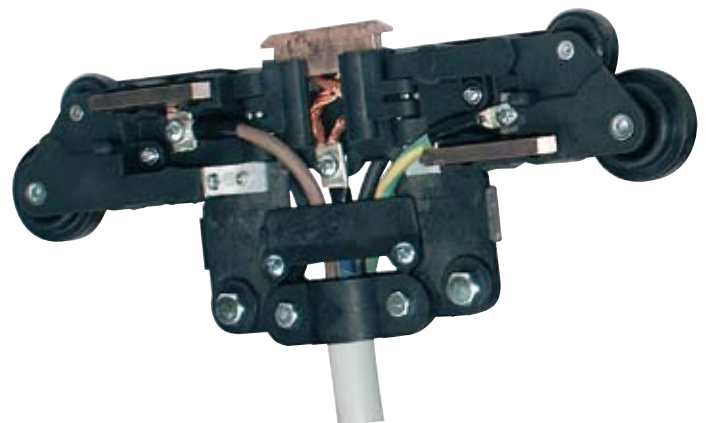
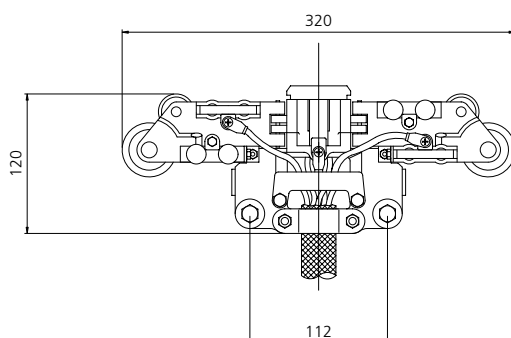

Line type C: continuous conductors - Line type P: pre-mounted conductors

25 Double current collector trolley with contact shoes, complete with coupling device - total amperage 70 A (2x35 A)

FEATURES: Line Type **C**

It is composed by 2 current collectors 35 A, connected through a coupling device.

CODE	AMPERAGE (A)	CONTACT SHOES N°
03.08027.94N	2x35 A	4
03.08027.95N		5

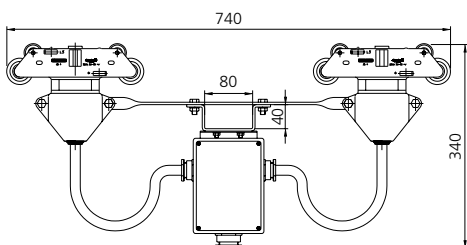

26 Double current collector trolley with contact shoes, complete with coupling device - total amperage 70 A (2x35 A)

FEATURES: Line Type **P**

It is composed by 2 current collectors 35 A, connected through a coupling device (towing arm cod. 03.08028.90 is not included).

CODE	AMPERAGE (A)	CONTACT SHOES N°
03.08027.94	2x35 A	4
03.08027.95		5

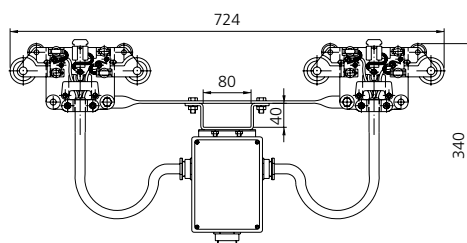

27 Double current collector trolley with contact shoes, complete with coupling device - total amperage 140 A (2x70 A)

FEATURES: Line Type **C/P**

It is composed by 2 current collectors 70 A, connected through a coupling device (towing arm cod. 03.08028.90 is not included).



CODE	AMPERAGE (A)	CONTACT SHOES N°
03.08041.94	2x70 A	4
03.08041.95		5

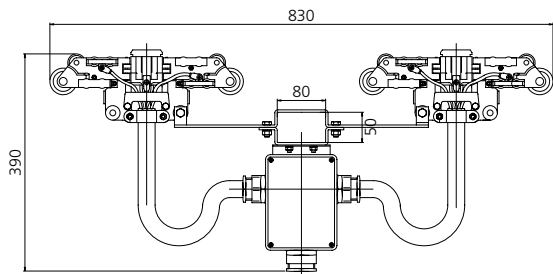

28 Current collector trolley for curves with 4 contact shoes 35 A

FEATURES: Line Type **C/P**

CODE: **03.08024.97C**

The body is completely insulated and the contact shoes are made of metal carbon. Equipped with 2 m. cable (the towing arm code 03.08026.90 and the towing arm attachment code 03.04019.90 are not included).

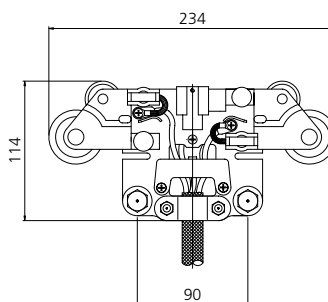
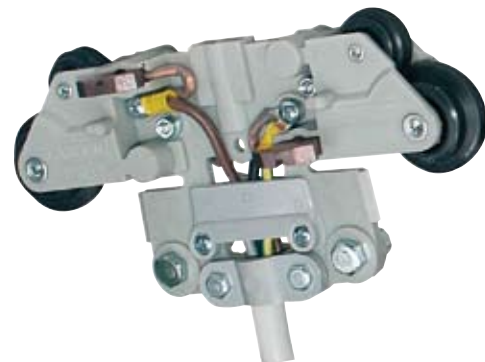

29 Towing arm attachment

FEATURES: Line Type **C/P**

Fixed to the trolley, it allows the coupling with the towing arm.

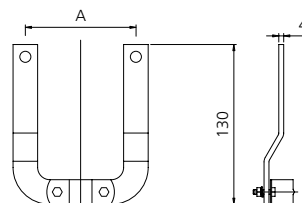

FOR TROLLEY CODE	"A"	CODE
03.08024.97C for curves 03.08024.92C5 - 93C5	90 mm.	03.04019.90
03.08024.92NC - 93NC	112 mm.	03.04019.91
03.08034.92C5 - 93C5	112 mm.	03.08025.91
03.08027.94 - 95	90 mm.	03.04019.90

Line type C: continuous conductors - Line type P: pre-mounted conductors

30 Towing arm

FEATURES: Line Type **C/P**

Fixed to the mobile machine it serves to tow the current collector trolley.

FOR TROLLEY CODE	"A"	CODE
03.08024.97C for curves 03.08024.92C5 - 93c5	140 mm.	03.08026.90
03.08024.92NC - 93NC	160 mm.	03.08026.91
03.08034.92C5 - 93C5	160 mm.	03.08026.91
03.08027.94N - 95N / 03.08027.94 - 95 / 03.0804194 - 95	70 mm.	03.08028.90

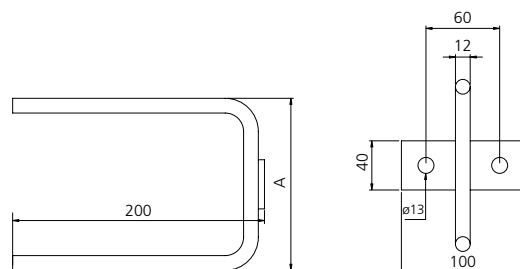

31 Current collector suspension device for transfer guide

FEATURES: Line Type **C/P**

CODE: **03.08020.90**

It serves to support the collector trolley and to facilitate its introduction into lines with transfer guide code 03.08031.90N.

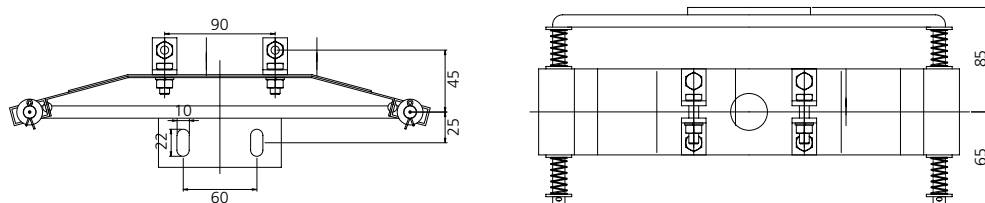

MOUNTING TOOLS

32 Roll holder plate

FEATURES: Line Type **C**

CODE: **03.08033.90**

Held on a support positioned at the same level of the contact line, it facilitates the unwinding of the conductor from the roll and the introduction into the insulating housing. Extremely light and easy to use.

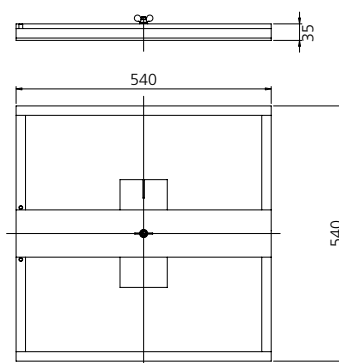

33 Trolley for the insertion of the conductor

FEATURES: Line Type C

CODE: **03.08030.90N**

Through a tension wire it serves to slide easily the conductor into the insulating housing.

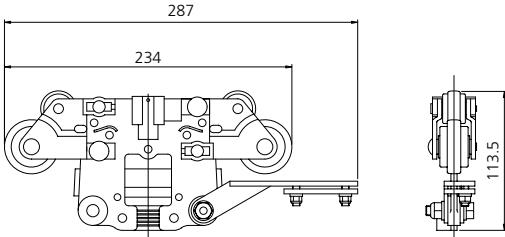

34 Trolley for the insertion of the simple strip for closure

FEATURES: Line Type C/P

CODE: **03.08008.90N**

Through a tension wire it serves to slide easily the simple strip for closure into the proper shaped seat places in the side lower of the insulating housing.

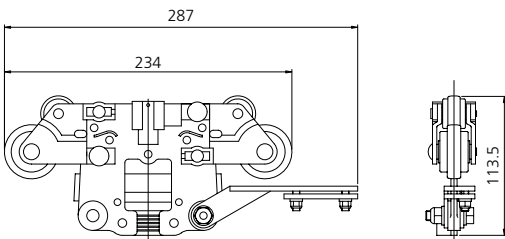

35 SUPPORT BRACKETS

FEATURES: Line Type C/P

Necessary to support the insulated feeding line it can be fixed to the track rail (type 1) or to the wall (type 2).

TYPE	"A"	CODE
1	350 mm.	03.08051.90
	500 mm.	03.08051.91
	700 mm.	03.08051.92
2	350 mm.	03.08052.90
	500 mm.	03.08052.91

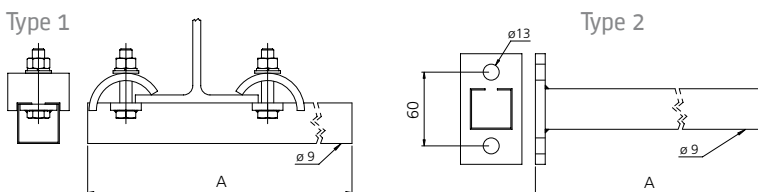

Line type C: continuous conductors - Line type P: pre-mounted conductors

SPARE PARTS

36 Contact conductor

Line Type **C**

CODE	AMPERAGE (A)
03.08009.90	70
03.08010.90	100
03.08011.90	140

37 Insulating housing

Line Type **C**

CODE	LENGTH
03.03006.90	4 mt.
03.03006.91	2 mt.

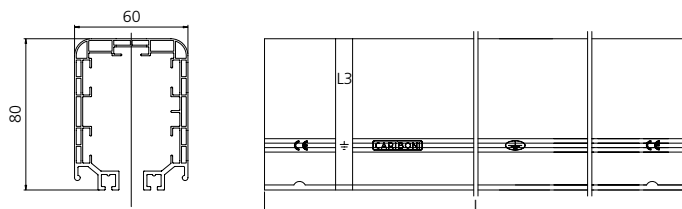

38 Contact shoes

Line Type **C/P**

FOR TROLLEY CODE	AMPERAGE (A)	CODE
03.08024.97C for curves 03.08024.92C5 - 93C5 for type P 03.08027.94 - 95 for type P	35	03.08036.90S
03.08024.92NC - 93NC for type C 03.08027.94N - 95N for type C	35	03.08056.90
03.08034.92C5 - 93C5 for type C e P 03.08041.94 - 95 for type C e P	70	03.08036.91

Example of a possible installation

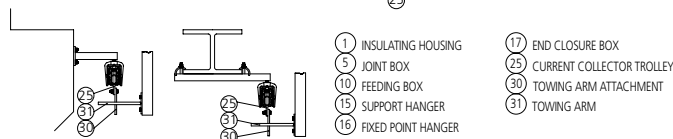
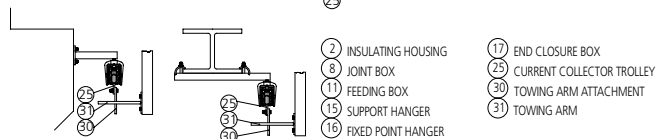
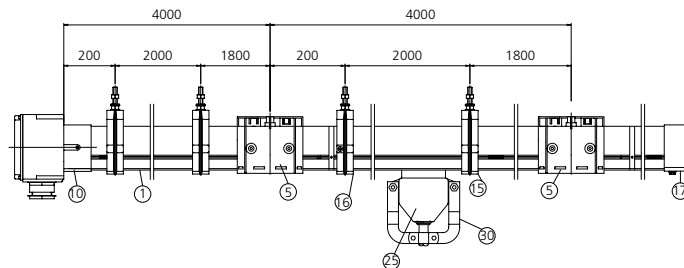
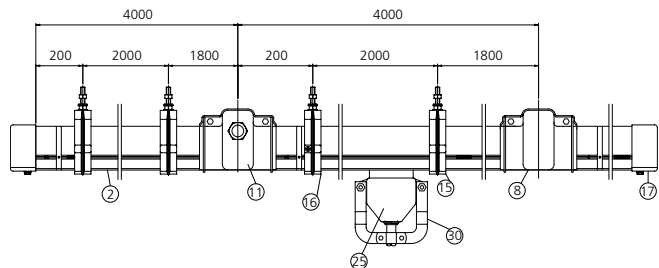

MINI ATOLLO[®] 40-60 A

Components

Line type C: continuous conductors - Line type P: pre-mounted conductors

LINE TYPE C: CONTINUOUS CONDUCTORS

FEATURES:

The contact conductors, cut according to the requested length, are inserted inside the housing as soon as it has been installed.

In this way an electrical line with continuous conductors has been realised with a considerable reduction of mounting time. This version guarantees also a minimum voltage drop as well as a reduced wear and tear of contact shoes. Inside the housing, a nib has been foreseen in order to avoid the wrong insertion of the trolley.

Line Type C: INSULATED HOUSING WITH CONTINUOUS CONDUCTORS			
L (m)	Conductors N°	Code	
		40 A	60 A
4	4	03.04044.90	03.04044.91
	5	03.04045.90	03.04045.91
2	4	03.04024.90	03.04024.91
	5	03.04025.90	03.04025.91

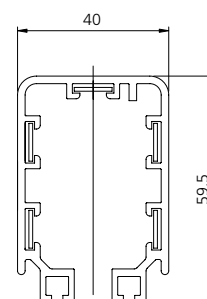

LINE TYPE P: PRE-MOUNTED CONDUCTORS

FEATURES:

The conductors are already inserted in the housing, inside the relevant seats. In order to facilitate the insertion, the extremities of the conductors have been bent and are ready for the joint with the relevant clamps.

Inside the housing, a nib has been foreseen in order to avoid the wrong insertion of the trolley.

Line Type P: PRE-MOUNTED CONDUCTORS			
L (m)	Conductors N°	Code	
		40 A	60 A
4	4	03.04244.90	03.04244.91
	5	03.04245.90	03.04245.91
2	4	03.04224.90	03.04224.91
	5	03.04225.90	03.04225.91

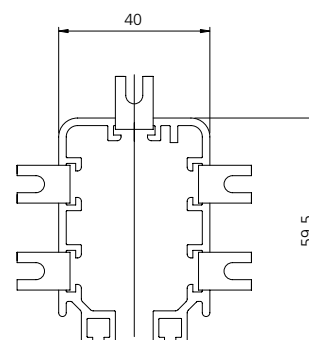

Line type C: continuous conductors - Line type P: pre-mounted conductors

All plastic components are made by insulating and self-extinguishing material.

39 Joint box for housing

FEATURES:

Line Type C

CODE: **03.04003.90**

It serves to connect two sections of the insulated housing. The release application is very easy and can be carried out without screws and it's equipped with 2 nibs, which guarantee a safe fixing on the housing.

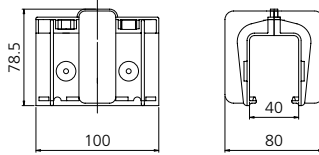

40 Joint box for fixed point

FEATURES:

Line Type C

CODE: **03.04004.90**

It serves to connect two sections of insulating housing. Fixed to the support bracket to ensure an even distribution of the expansion.

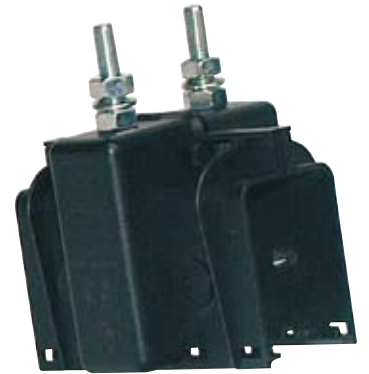
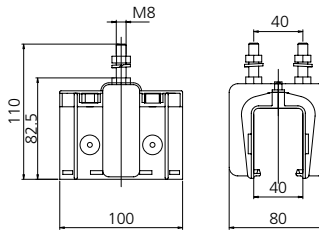

41 Joint clamp

FEATURES:

Line Type C

CODE: **03.04015.90**

Used for the connection of conductors in case of extension of existing lines or of lines particularly long, where the conductor cannot be inserted in one operation.

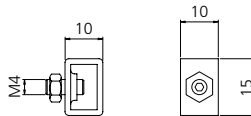

42 Joint box for housing

FEATURES:

Line Type P

CODE: **03.04005.90**

It serves to connect two sections of the insulating housing in case of line type P (pre-mounted conductors).

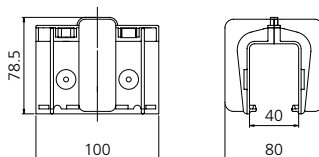

43 Joint clamp

FEATURES: Line Type P

CODE: **03.04016.90**

It serves to join the contact conductors in case of line type P (pre-mounted conductors). It is inserted in the copper, which has already been prepared for the assembling.

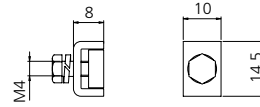

44 End feeder box

FEATURES: Line Type C

CODE: **03.04007.90**

It is mounted at the end of the line. The removal of the back cover allows an easier installation.

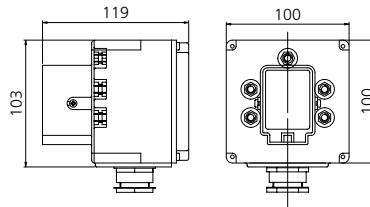

45 Line feeder box

FEATURES: Line Type C/P

CODE: **03.04006.90**

It can be mounted on each point of the line nearby the junction of 2 housing sections.

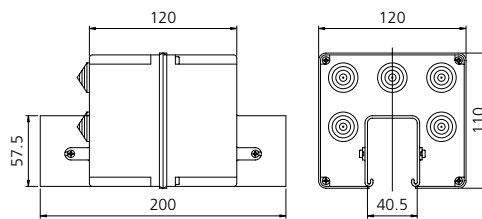

46 Terminal connector for feeder cable

FEATURES: Line Type C/P

CODE: **8.14.00.0037-8.14.00.0038**

Inserted in the joint clamp, it serves to connect the cable to the conductor, inside the line feeder box.

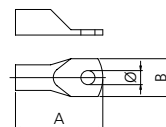

CODE	AMPERAGE (A)	DIMENSIONS mm.			MAX. CABLE SECTION (mm ²)
		A	B	Ø	
8.14.00.0037	40	23	10	4,25	6
8.14.00.0038	60	26	10	4,25	10

47 Support hanger

FEATURES:

Line Type **C/P**

CODE: **03.04008.90**

It permits the creep of the insulating housing due to expansion. The installation distance between two support hangers must be max. 1,33m.

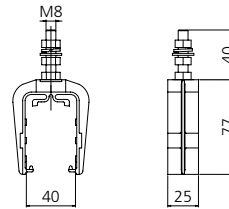

48 Fixed point hanger

FEATURES:

Line Type **C/P**

CODE: **03.04009.90**

Locked to the housing with two lateral screws, it serves to obtain a fixed point so to ensure an even distribution of the expansion.

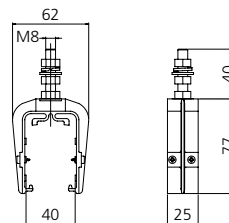

49 End closure box

FEATURES:

Line Type **C/P**

CODE: **03.04010.90**

It serves to close the end of the line and is fixed to the insulating housing.

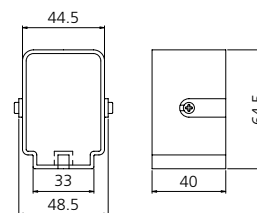

50 Simple strip for closure

FEATURES:

Line Type **C/P**

CODE: **03.04011.91**

Two flexible sealing strips, passed through the side grooves of the housing, will give an additional protection of the contact line from IP 13 to IP 23.

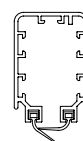

Line type C: continuous conductors - Line type P: pre-mounted conductors

51 Inspection point

FEATURES: Line Type **C**

CODE: **03.04020.90**

It consists in a removable housing section, which allows the inspection and the eventual removal of the collector trolley. For the mounting 2 further support brackets must be foreseen.

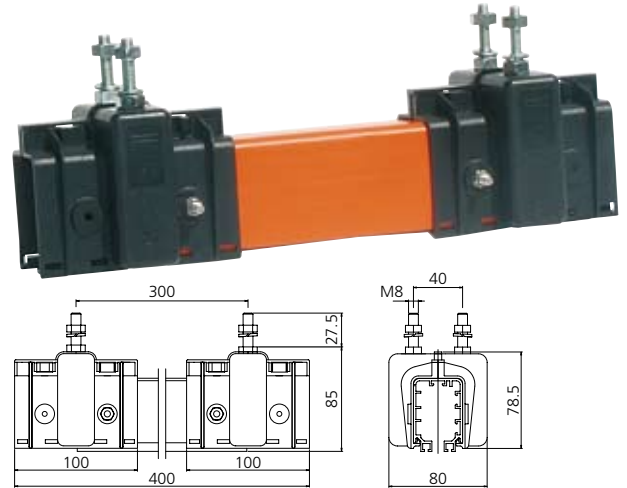

52 Sectionalizing joint

FEATURES: Line Type **C/P**

CODE: **03.04013.90**

It permits to divide electrically the line in various sections, in order to create insulated maintenance areas.

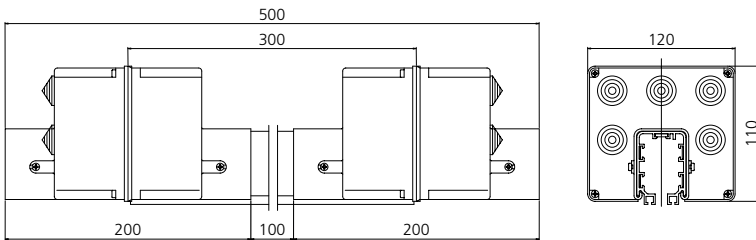

53 Transfer guide for collector trolley

FEATURES: Line Type **C/P**

CODE: **03.04027.90**

It serves to facilitate the insertion of the current collector in case of interrupted line.

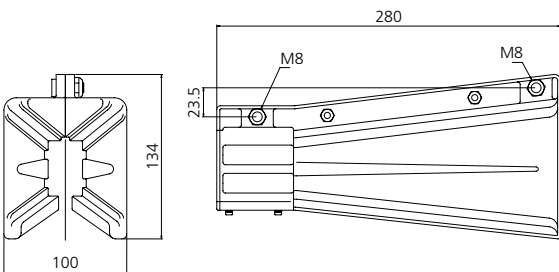

54 Alignment plates

FEATURES: Line Type **C/P**

CODE: **5.090301.08**

Inserted in the side grooves of the housing, they ensure a perfect alignment nearby the junctions and an optimization of the current collector sliding.



55 Current collector trolley with contact shoes 25 A

FEATURES: Line Type **C/P**

The body is completely insulated and the contact shoes are made of metal carbon. Equipped with 5 m. cable and towing arm attachment (the towing arm code 03.08026.90 is not included). Inside there is a terminal box, that can be easily reached for any eventual maintenance, without removing the current collector from the insulating housing. In case of Amperage more than 25 A, a parallel connection with 2 or more collectors is necessary or, as alternative, a current collector trolley for higher amperages can be used as per the following table:

CODE	AMPERAGE (A)	CONTACT SHOES N°
03.04018.94C	25 A	4
03.04018.95C		5

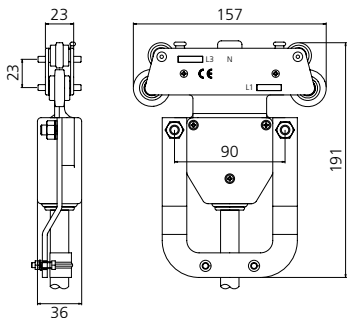

56 Double current collector trolley with contact shoes, complete with coupling device - total amperage 50 A (2x25 A)

FEATURES: Line Type **C/P**

It is composed by 2 current collectors 25 A, connected through a coupling device.

CODE	AMPERAGE (A)	CONTACT SHOES N°
03.04021.94	2x25 A	4
03.04021.95		5

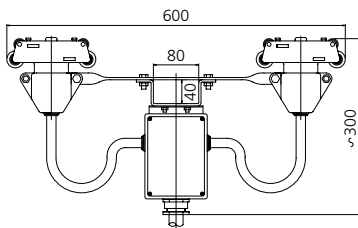

Line type C: continuous conductors - Line type P: pre-mounted conductors

57 Towing arm attachment

FEATURES: Line Type C/P

Fixed to the trolley, it allows the coupling with the towing arm.

FOR TROLLEY CODE	"A"	CODE
03.04018.94C - 95C	90 mm.	03.04019.90

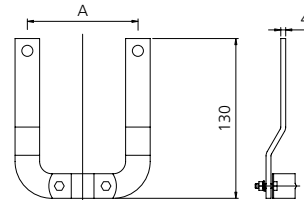

58 Towing arm

FEATURES: Line Type C/P

Fixed to the mobile machine it serves to tow the current collector trolley.

FOR TROLLEY CODE	"A"	CODE
03.04018.94C - 95C	140 mm.	03.08026.90
03.04021.94C - 95C	70 mm.	03.08028.90

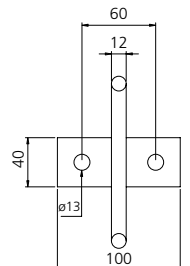
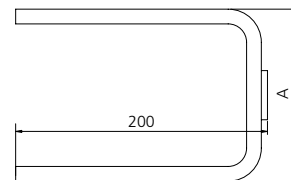

59 Current collector suspension device for transfer guide

FEATURES: Line Type C/P

CODE: **03.04028.90**

It serves to support the collector trolley and to facilitate its introduction into lines with transfer guide code 03.04027.90.

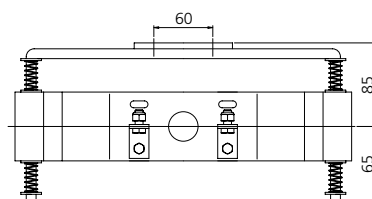
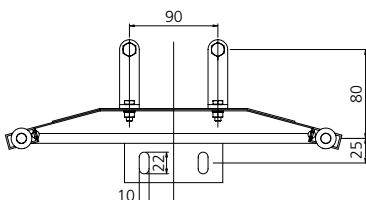

MOUNTING TOOLS

60 Roll holder plate

FEATURES:

Line Type **C**

CODE: **03.04032.90**

Held on a support positioned at the same level of the contact line, it facilitates the unwinding of the conductor from the roll and the introduction into the insulating housing. Extremely light and easy to use.

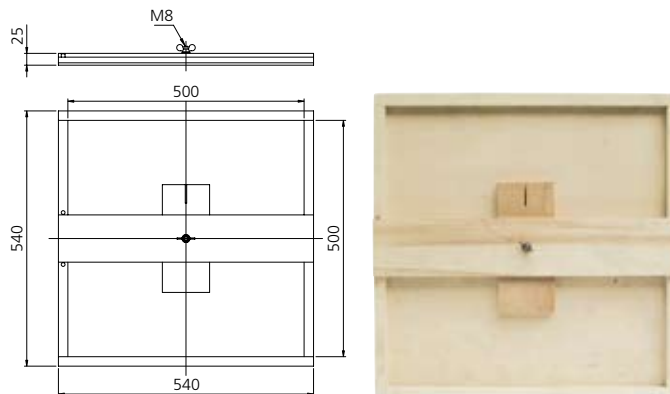

61 Trolley for the insertion of the conductor and for the insertion of the simple strip for closure

FEATURES:

Line Type **C/P**

CODE: **03.04029.90**

Through a tension wire it serves to slide easily the simple strip for closure into the proper shaped seats in the side lower of the insulating housing.

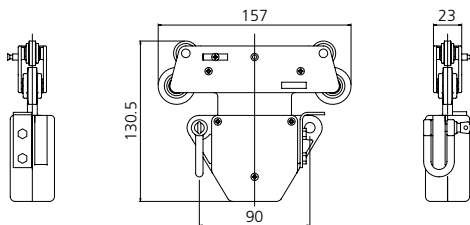

SPARE PARTS

62 Contact conductor

Line Type **C**

CODE	AMPERAGE (A)
03.04001.90	40
03.04001.91	60

63 Insulating housing

Line Type **C**

CODE	LENGTH
03.04000.90	4 mt.
03.04000.91	2 mt.

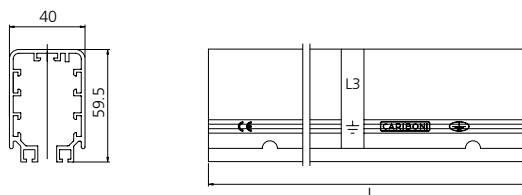

64 Contact shoes

Line Type **C/P**

CODE	AMPERAGE (A)
03.04026.90NH	25

Line type C: continuous conductors - Line type P: pre-mounted conductors

Example of a possible installation

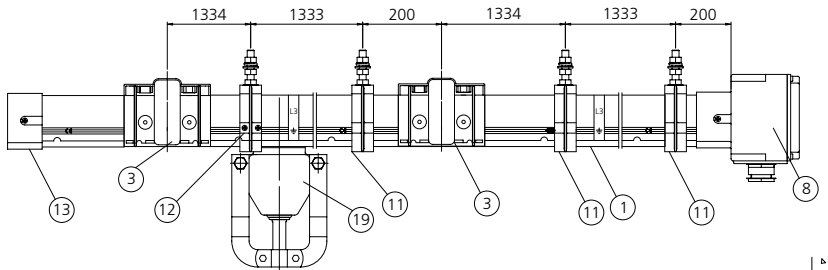

- ① INSULATOR
- ③ JOINT BOX
- ⑧ FEEDING BOX
- ⑪ SUPPORT HANGER
- ⑫ FIXED POINT HANGER
- ⑬ END CLOSURE BOX
- ⑱ CURRENT COLLECTOR
- ⑳ TOWING ARM

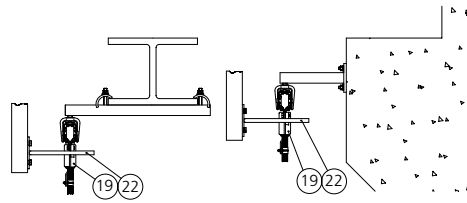



OSVALDO CARIBONI LECCO S.p.A. a Socio Unico
I- 23855 Pescate (LC) Via Roma, 14
Tel. ++39/0341.358711 - Fax ++39/0341.364672
E-mail: info@cariboni.it - <http://www.cariboni.it>